

DEFINITIVE SITE PLAN

FOR

39 LAMARTINE STREET

WORCESTER, MASSACHUSETTS 01610

RECORD APPLICANT:
 POLAR VIEWS, LLC
 89 WEST MAIN STREET UNIT 101
 NORTHBOROUGH, MA 01532

RECORD OWNER:
 POLAR VIEWS, LLC
 89 WEST MAIN STREET UNIT 101
 NORTHBOROUGH, MA 01532

LAND PLANNERS—CIVIL ENGINEERS:
 J.M. GRENIER ASSOCIATES INC.
 118 TURNPIKE ROAD SUITE 200
 SOUTHBOROUGH, MA 01772
 (508) 845-2500

LAND SURVEYORS:
 GEO/NETWORK LAND SURVEY INC.
 645 CHANDLER STREET SUITE 7
 WORCESTER, MA 01610

ZONING DISTRICT: BUSINESS, GENERAL (BG-3.0)

INDEX DESCRIPTION	SHEET NUMBER
COVER	1 OF 8
EXISTING CONDITIONS PLANS	2 OF 8
LAYOUT PLAN	3 OF 8
GRADING AND DRAINAGE PLAN	4 OF 8
UTILITY PLAN	5 OF 8
EROSION & SEDIMENTATION CONTROL PLAN	6 OF 8
DETAIL PLAN	7 OF 8
DETAIL PLAN	8 OF 8



2	10/30/24	ZBA CONDITIONS OF APPROVAL
1	9/10/24	CITY COMMENTS
REV. NO.	DATE	REVISION
SCALE:		DATE:
AS SHOWN		JUNE 6, 2024
COVER SHEET		
SHEET NO.:		PROJECT NO.:
SHEET 1 OF 8		G-647

PLAN REFERENCES

PLAN BOOK 474 PLAN 123
 PLAN BOOK 842 PLAN 40
 PLAN BOOK 845 PLAN 105

CITY OF WORCESTER PLANS
 LAMARTINE STREET (H-15 6741-1)
 MEADE STREET (H-9286)
 GROSVENOR STREET (H-9323)

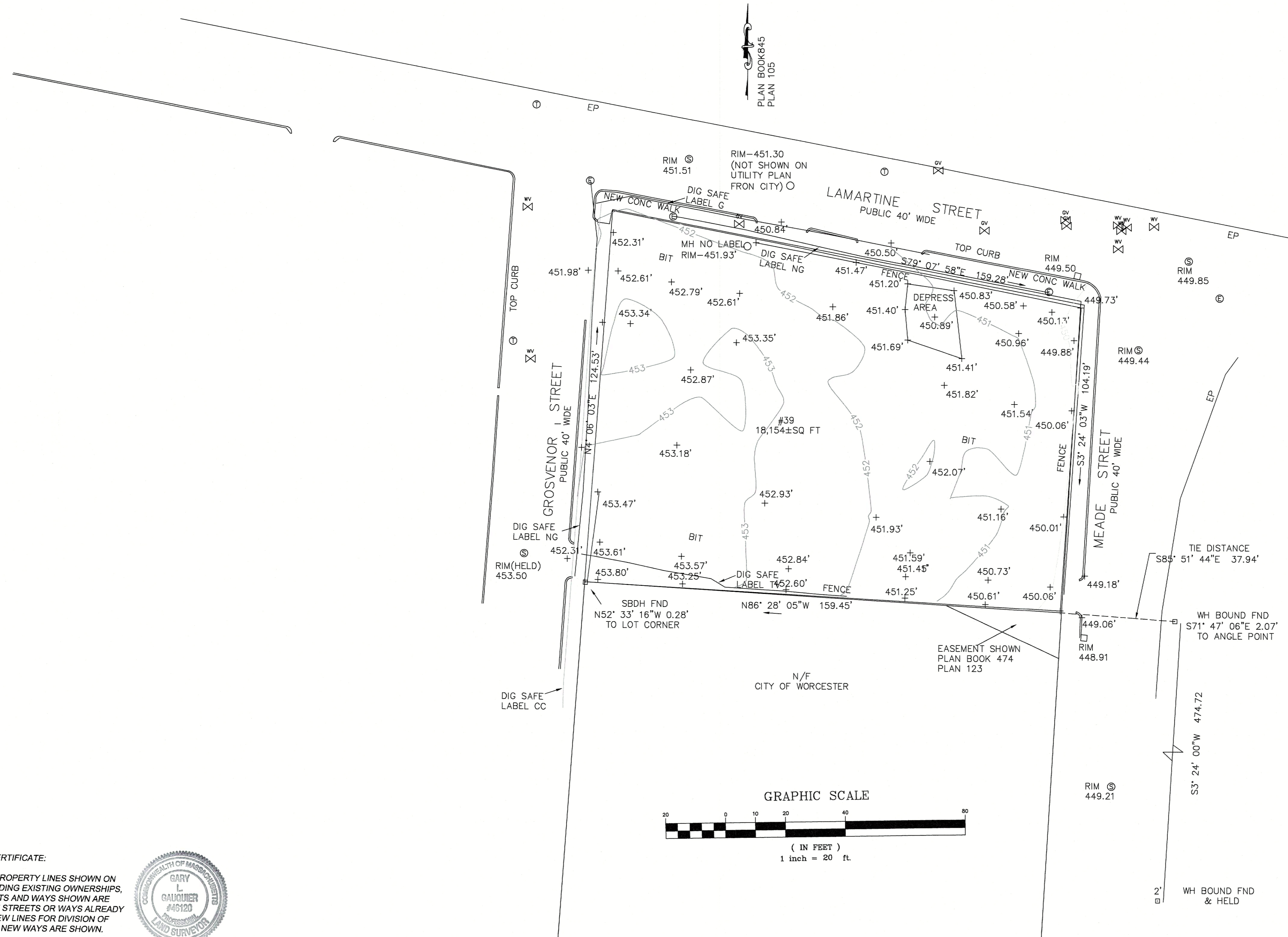
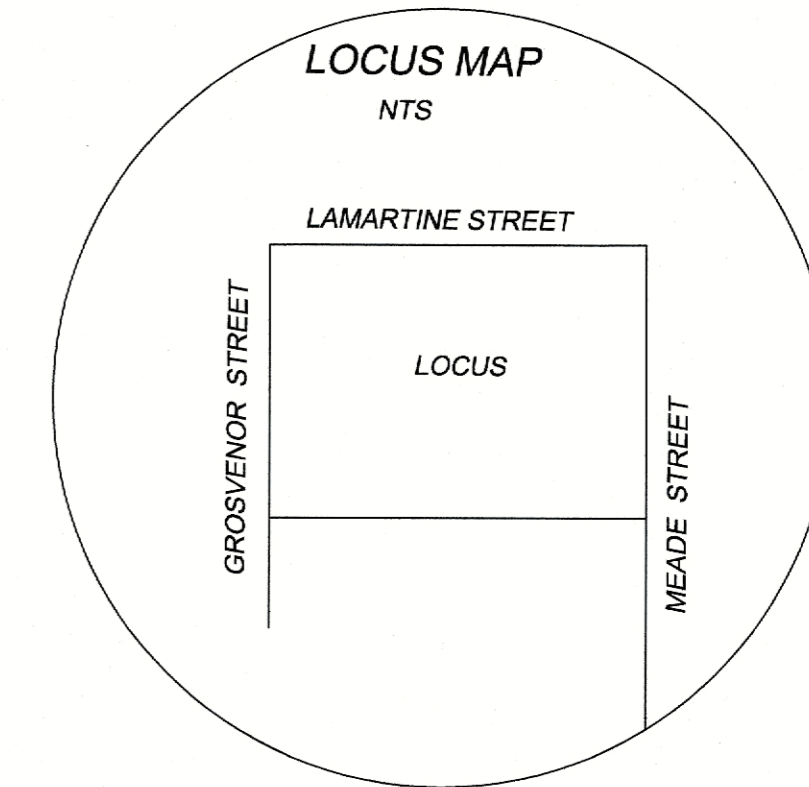

- NOTES**
- 1.) DATUM TAKEN FROM SMH ON UTILITY PLAN FROM CITY OF WORCESTER
 - 2.) CONSTRUCTION ON LOTS OR LAND IS SUBJECT TO ANY EASEMENTS, RIGHT OF WAYS, RESTRICTION RESERVATIONS OR LIMITATIONS ON RECORD
 - 3.) UTILITIES SHOWN ARE FROM FIELD LOCATIONS IT SHALL BE THE RESPONSIBILITY OF THE DESIGN ENGINEER AND THE CONTRACTOR TO VERIFY THE SIZE, ELEVATION AND LOCATION, AND TO CONTACT "DIG-SAFE" AT LEAST 72 HOURS PRIOR TO ANY EXCAVATION, DEMOLITION OR CONSTRUCTION

OWNER OF RECORD
 39 LAMARTINE STREET LLC
 DEED BOOK 66121 PAGE 388

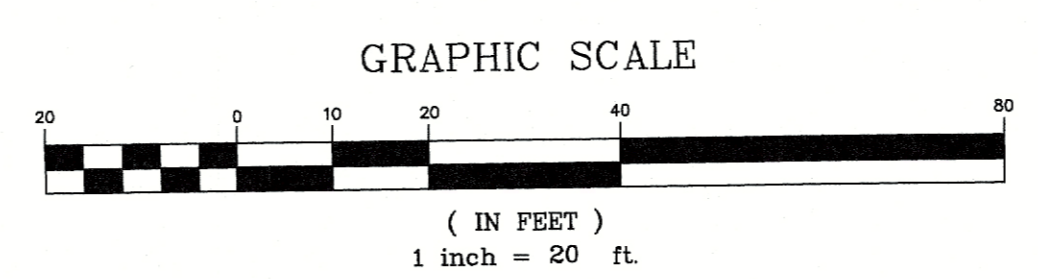

MGL C41 S81X SURVEYOR'S CERTIFICATE:

I HEREBY CERTIFY THAT THE PROPERTY LINES SHOWN ON THIS PLAN ARE THE LINES DIVIDING EXISTING OWNERSHIPS, AND THE LINES OF THE STREETS AND WAYS SHOWN ARE THOSE OF PUBLIC OR PRIVATE STREETS OR WAYS ALREADY ESTABLISHED AND THAT NO NEW LINES FOR DIVISION OF EXISTING OWNERSHIP OR FOR NEW WAYS ARE SHOWN.



2/29/24
 DATE SURVEYOR *Gary L. Gaudier*

PLAN OF LAND
 39 LAMARTINE STREET
 WORCESTER, MA
 PREPARED FOR: DANIEL AND REBECCA YARNIE
 FEBRUARY 24, 2024 SCALE 1" = 20'
GEO / NETWORK LAND SURVEY, INC.
 645 CHANDLER STREET SUITE 7
 WORCESTER, MASSACHUSETTS 01610
 508-755-7003 FAX 508-755-8003

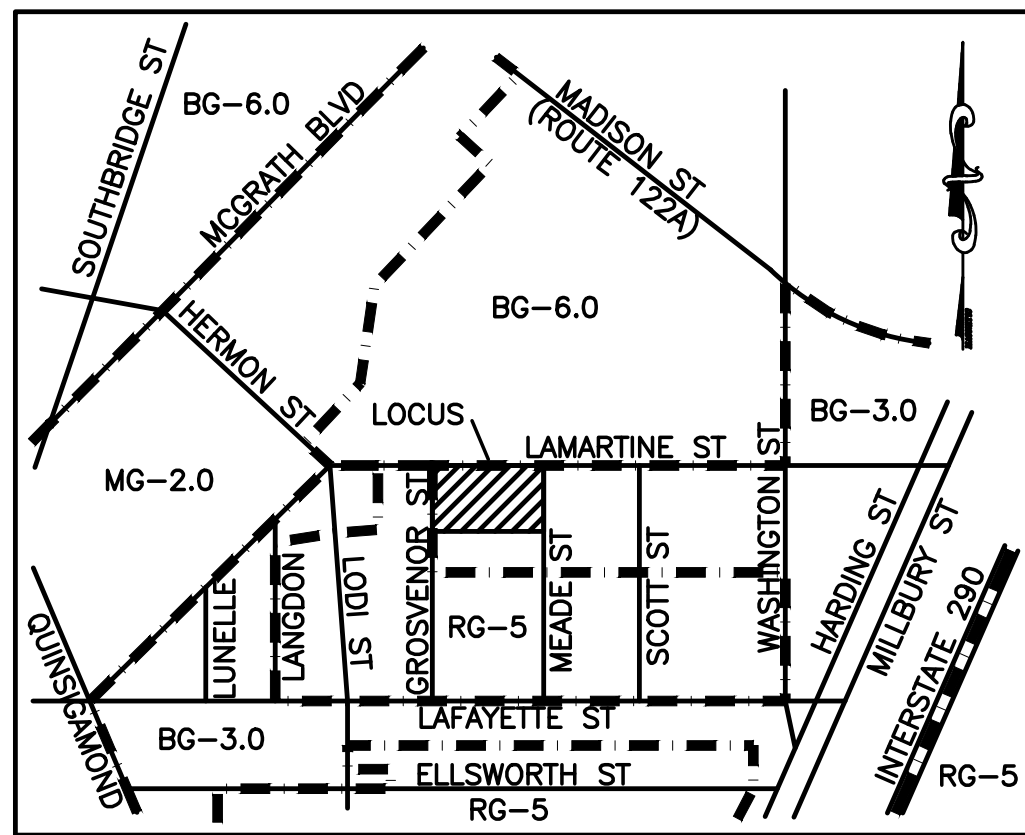

LOCUS: N.T.S.

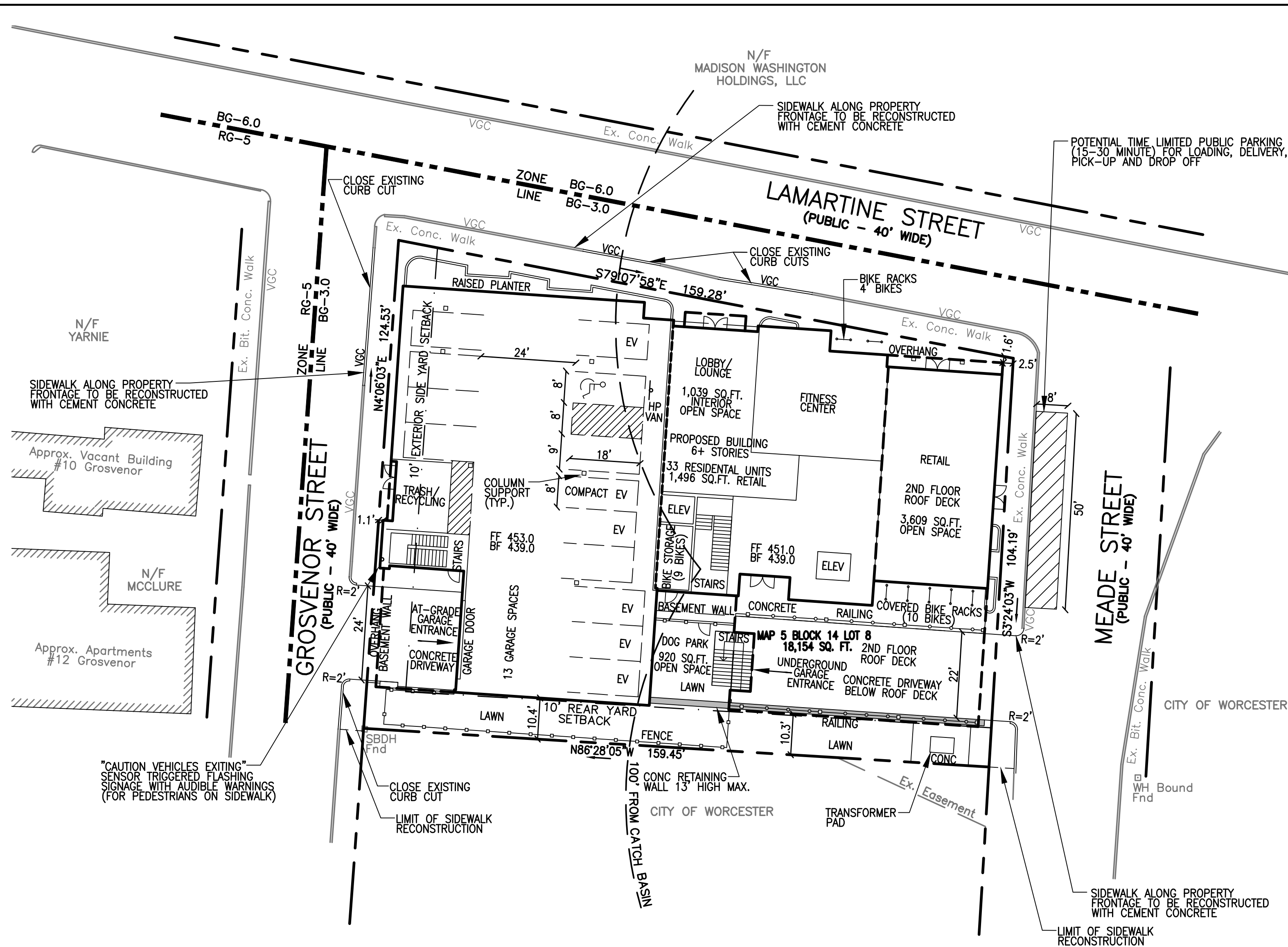

AT-GRADE LAYOUT

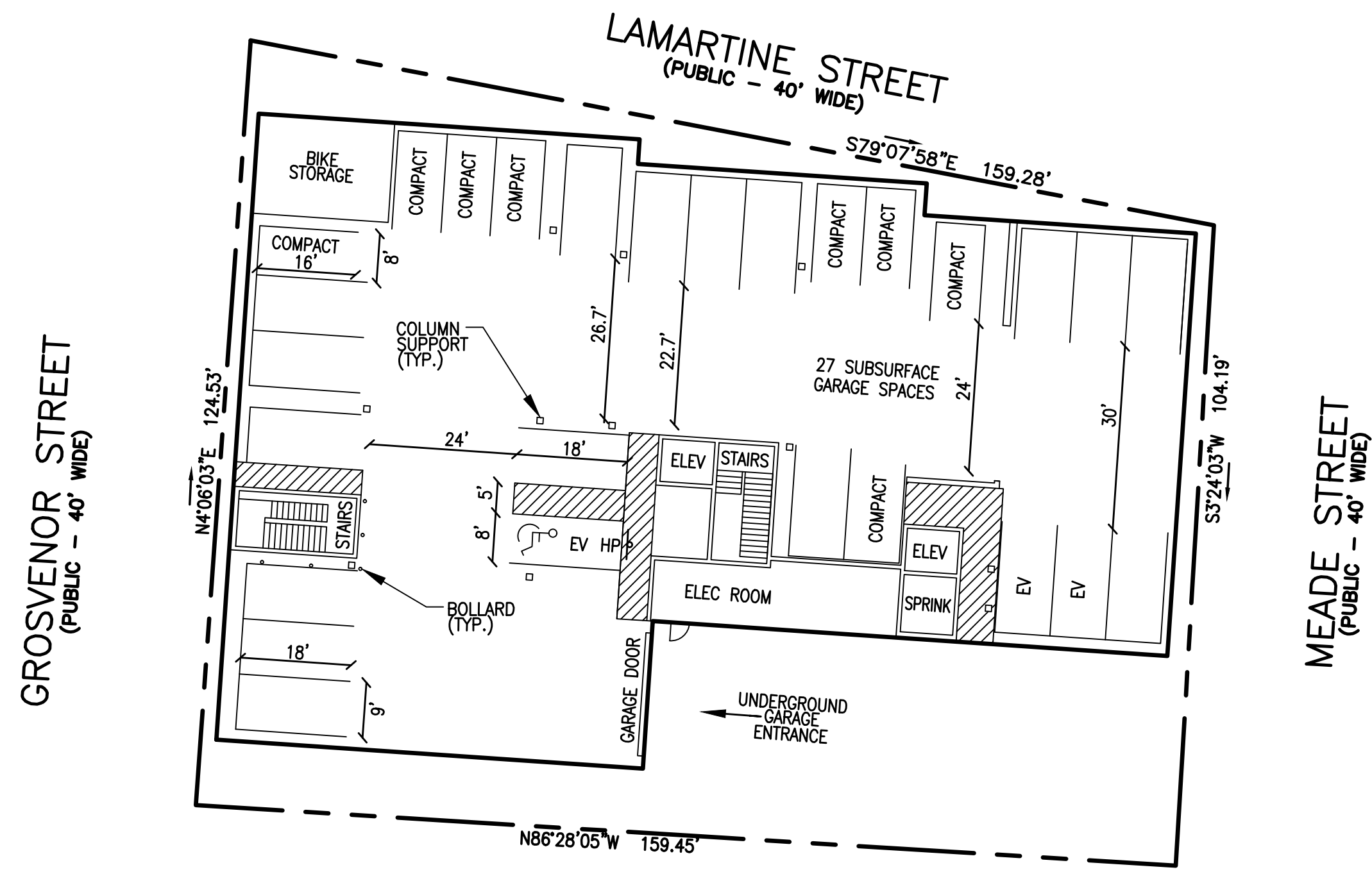

SUBSURFACE PARKING LAYOUT

ZONING SUMMARY

CURRENT ZONE: BUSINESS, GENERAL (BG-3.0)

	REQUIRED RESIDENTIAL	REQUIRED NON-RESIDENTIAL	PROPOSED
MIN. LOT AREA	5,000 SQ.FT.	--	18,154 SQ.FT.
LOT REGULARITY FACTOR*	0.4	0.4	0.969
MIN. FRONTAGE	200'	--	159.28'
MIN. FRONT YARD SETBACK	--	--	1.6'
MIN. EXTERIOR SIDE YARD SETBACK 0'/10'	0'/10'	0'/10'	2.5'/1.1'
MIN. REAR YARD SETBACK	10'	10'	10.3'
MIN. RECREATION AREA	10%/1,815 SQ.FT.	--	24.9%/4,529 SQ.FT.
MAX. FLOOR AREA RATIO	3.0	3.0	2.91
MAX. BUILDING HEIGHT	100'	100'	68'

* R=16*A/P^2, WHERE A=AREA AND P=PERIMETER

USE	REQUIRED
MULTI-FAMILY: 2/D.U X 33 UNITS	= 66 SPACES*0.75 = 50 SPACES*
RETAIL: 1/300 SQ.FT. X 1,496 SQ.FT.	= 5 SPACES
	55 SPACES REQUIRED
	40 SPACES PROVIDED
	(30 STANDARD SPACES
	9 COMPACT SPACES (22%))

* 25% PARKING REDUCTION FOR ELIGIBLE DEVELOPMENT UNDER ARTICLE VII SECTION 6.A.II.a OF THE ZONING ORDINANCE

NOTES:

- VARIANCE REQUIRED FROM ZONING BOARD OF APPEALS TO REDUCE FRONTAGE FROM 200' TO 159.28'
- VARIANCE REQUIRED FROM ZONING BOARD OF APPEALS TO REDUCE EXTERIOR SIDE YARD SETBACK ABUTTING RG-5 ZONING DISTRICT FROM 10' TO 1.1'
- SPECIAL PERMIT REQUIRED FROM PLANNING BOARD FOR PARKING SPACE REDUCTION OF UP TO 50% OF BASE REQUIREMENT
- SPECIAL PERMIT REQUIRED FROM PLANNING BOARD TO REDUCE DRIVING AISLE WIDTH FROM 24' TO 22'.
- SPECIAL PERMIT REQUIRED FROM PLANNING BOARD FOR RELIEF FROM LOADING SPACE REQUIREMENTS IN TABLE 4.5. ONE LOADING SPACE IS PROPOSED ON MEADE STREET.

LEGEND:

- EXISTING PROPERTY LINE
- EXISTING EASEMENT LINE
- 450--- EXISTING CONTOUR - HIGH
- 448--- EXISTING CONTOUR - LOW
- 450--- PROPOSED CONTOUR - HIGH
- 448--- PROPOSED CONTOUR - LOW
- EXISTING EDGE PAVEMENT
- EXISTING CURB
- PROPOSED EDGE OF PAVEMENT
- PROPOSED CURB
- D --- EXISTING DRAIN LINE
- D --- PROPOSED DRAIN LINE
- FM --- PROPOSED FORCE MAIN
- W --- EXISTING WATER LINE
- W --- PROPOSED WATER LINE
- S --- EXISTING SEWER LINE
- S --- PROPOSED SEWER LINE
- G --- EXISTING GAS LINE
- G --- EXISTING UNDERGROUND ELECTRIC
- G --- EXISTING UNDERGROUND CABLE TV
- PROPOSED EROSION CONTROL

NOTE:

WRTA ROUTE 4 IS LOCATED WITHIN WALKING DISTANCE SUBJECT PROPERTY (AT MILLBURY/LAFAYETTE, HARDING/LAFAYETTE).

GRAPHIC SCALE

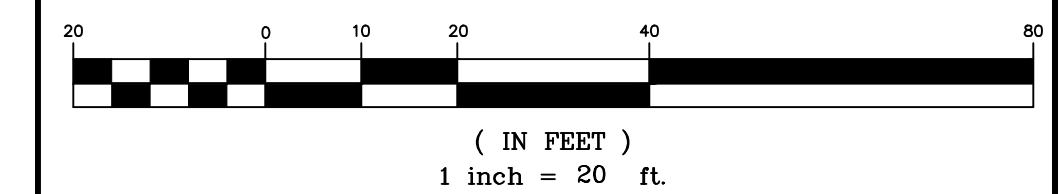

2	10/30/24	ZBA CONDITIONS OF APPROVAL
1	9/10/24	CITY COMMENTS
REV. NO.	DATE	REVISION

TITLE:
DEFINITIVE SITE PLAN
FOR
39 LAMARTINE STREET
WORCESTER, MASSACHUSETTS 01610

PREPARED FOR:
POLAR VIEWS, LLC
89 WEST MAIN STREET UNIT 101
NORTHBOROUGH, MASSACHUSETTS 01532

PROPERTY OWNER:
POLAR VIEWS, LLC
89 WEST MAIN STREET UNIT 101
NORTHBOROUGH, MASSACHUSETTS 01532

PREPARED BY:
J.M. GRENIER ASSOCIATES INC.
118 TURNPIKE ROAD SUITE 200
SOUTHBOROUGH, MASSACHUSETTS 01772

TELE NO.: (508) 845-2500 jmgrenier@townisp.com

SCALE: 1" = 20' DATE: JUNE 6, 2024

LAYOUT PLAN

SHEET NO.: SHEET 3 OF 8 PROJECT NO.: G-647



10/30/24

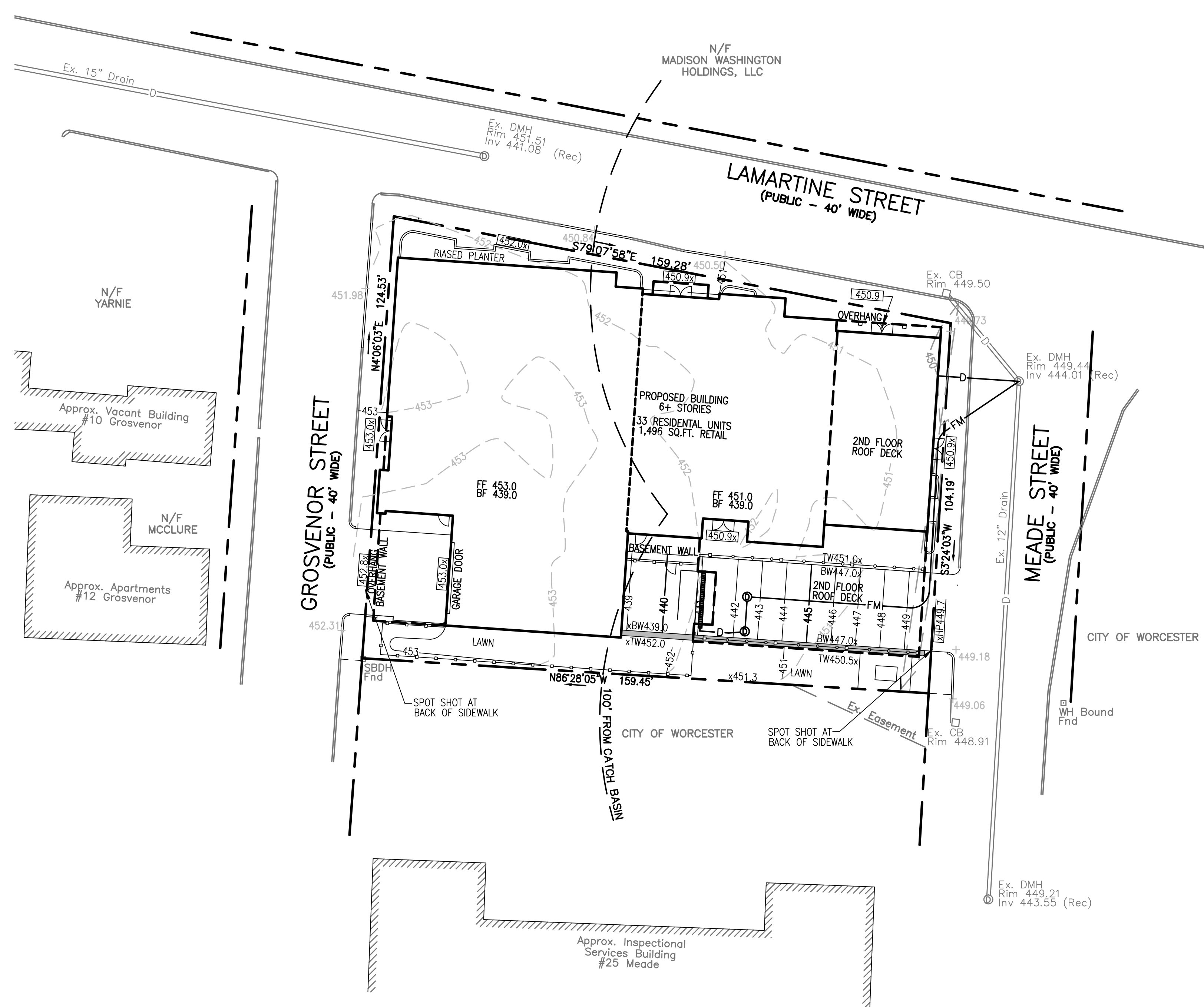

LEGEND:

---	EXISTING PROPERTY LINE
---	EXISTING EASEMENT LINE
-450-	EXISTING CONTOUR - HIGH
-448-	EXISTING CONTOUR - LOW
-450-	PROPOSED CONTOUR - HIGH
-448-	PROPOSED CONTOUR - LOW
---	EXISTING EDGE PAVEMENT
---	EXISTING CURB
---	PROPOSED EDGE OF PAVEMENT
---	PROPOSED CURB
D	EXISTING DRAIN LINE
D	PROPOSED DRAIN LINE
FM	PROPOSED FORCE MAIN
W	EXISTING WATER LINE
W	PROPOSED WATER LINE
S	EXISTING SEWER LINE
S	PROPOSED SEWER LINE
G	EXISTING GAS LINE
E	EXISTING UNDERGROUND ELECTRIC
C	EXISTING UNDERGROUND CABLE TV
---	PROPOSED EROSION CONTROL

- NOTES:**
- EXISTING CONDITIONS SURVEY BY GEO/NETWORK LAND SURVEY INC. 645 CHANDLER STREET SUITE 7 WORCESTER, MA 01610.
 - REFERENCE CITY OF WORCESTER ASSESSOR'S MAP 5 BLOCK 14 LOT 8.
 - REFERENCE WORCESTER REGISTRY OF DEEDS BOOK 67447 PAGE 1.
 - DATUM IS NAVD88.
 - EXISTING SOILS ON SITE ARE URBAN LAND.

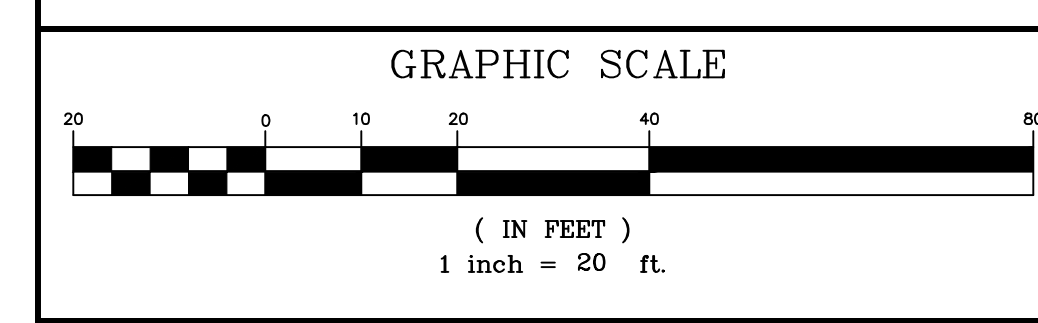

REV. NO.	DATE	REVISION
2	10/30/24	ZBA CONDITIONS OF APPROVAL
1	9/10/24	CITY COMMENTS

TITLE:
DEFINITIVE SITE PLAN
FOR
39 LAMARTINE STREET
WORCESTER, MASSACHUSETTS 01610

PREPARED FOR:
POLAR VIEWS, LLC
89 WEST MAIN STREET UNIT 101
NORTHBOROUGH, MASSACHUSETTS 01532

PROPERTY OWNER:
POLAR VIEWS, LLC
89 WEST MAIN STREET UNIT 101
NORTHBOROUGH, MASSACHUSETTS 01532

PREPARED BY:
J.M. GRENIER ASSOCIATES INC.
118 TURNPIKE ROAD SUITE 200
SOUTHBOROUGH, MASSACHUSETTS 01772
 TELE NO.: (508) 845-2500 jmgrenier@townisp.com

SCALE: 1" = 20'
DATE: JUNE 6, 2024

GRADING AND DRAINAGE PLAN

SHEET NO.: SHEET 4 OF 8
PROJECT NO.: G-647

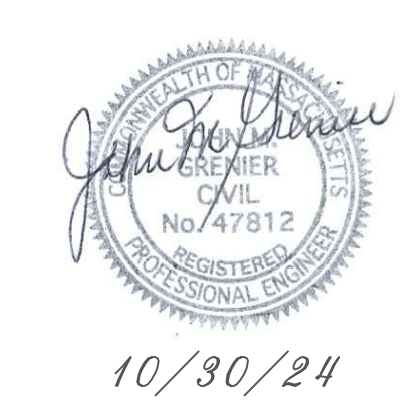

10/30/24

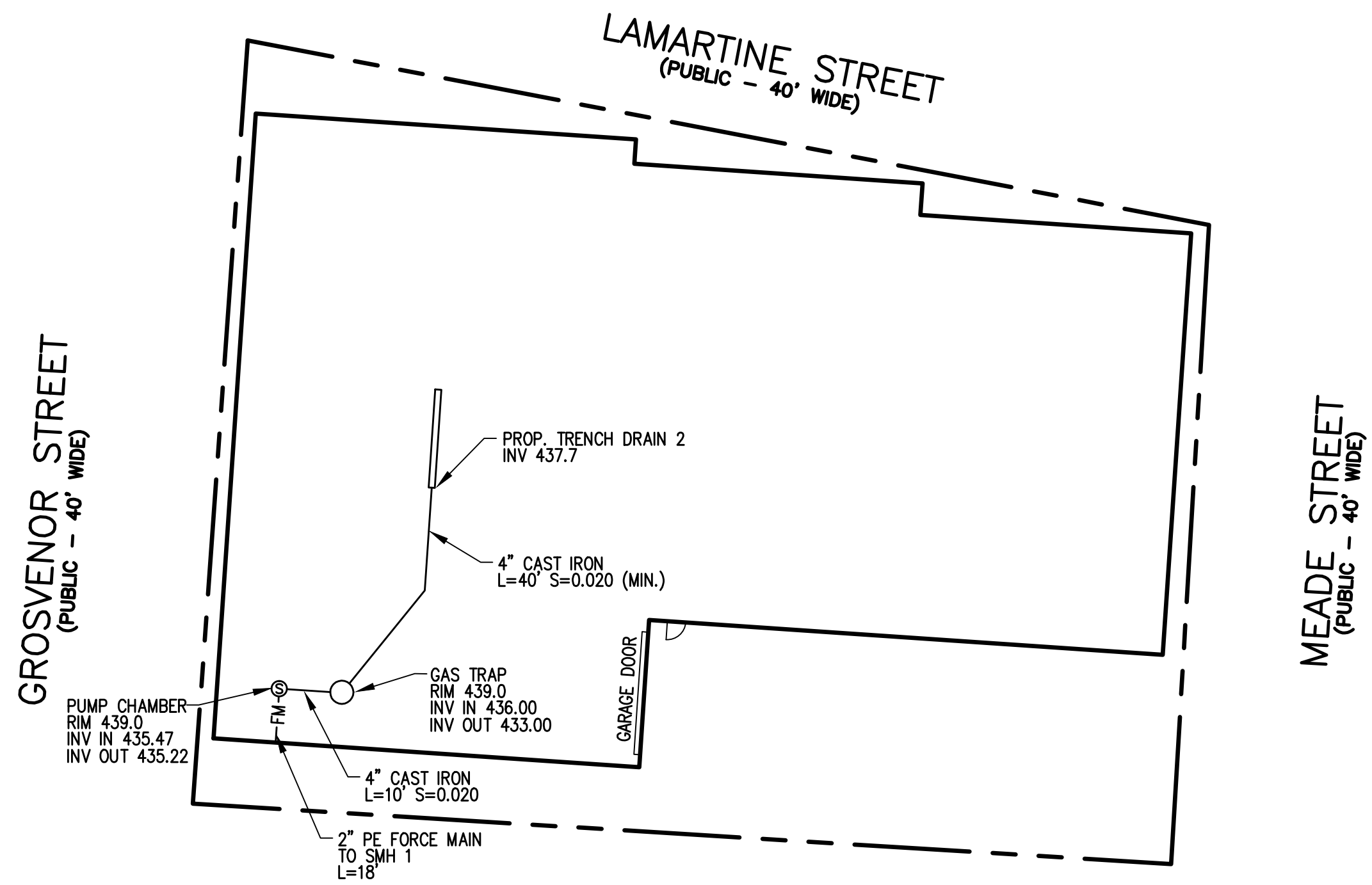
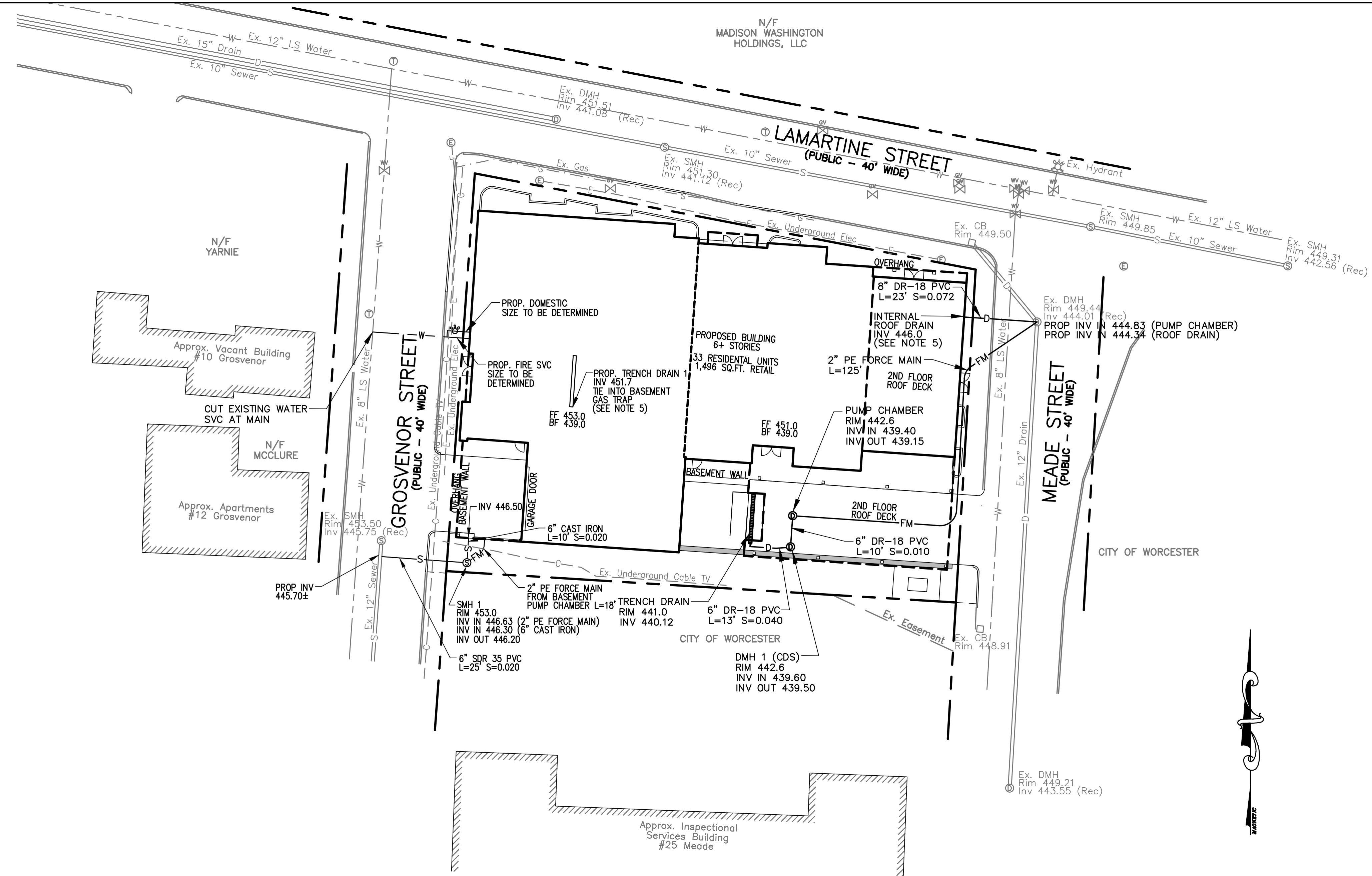

LEGEND:

- EXISTING PROPERTY LINE
- EXISTING EASEMENT LINE
- - - 450 --- EXISTING CONTOUR - HIGH
- - - 448 --- EXISTING CONTOUR - LOW
- - - 450 --- PROPOSED CONTOUR - HIGH
- - - 448 --- PROPOSED CONTOUR - LOW
- EXISTING EDGE PAVEMENT
- EXISTING CURB
- PROPOSED EDGE OF PAVEMENT
- PROPOSED CURB
- D --- EXISTING DRAIN LINE
- D --- PROPOSED DRAIN LINE
- FM --- PROPOSED FORCE MAIN
- W --- EXISTING WATER LINE
- W --- PROPOSED WATER LINE
- S --- EXISTING SEWER LINE
- S --- PROPOSED SEWER LINE
- G --- EXISTING GAS LINE
- E --- EXISTING UNDERGROUND ELECTRIC
- C --- EXISTING UNDERGROUND CABLE TV
- PROPOSED EROSION CONTROL

- NOTES:**
- ALL TRENCHES WITHIN GROSVENOR, LAMARTINE AND MEADE STREETS SHALL BE BACKFILLED AS REQUIRED BY THE CITY OF WORCESTER.
 - EXISTING CATCH BASINS WITHIN 100' OF THE PROPERTY MUST BE PROTECTED WITH INLET PROTECTION AT ALL TIMES UNTIL THE SITE IS FULLY STABILIZED.
 - SEWER SHALL BE INSTALLED WITH A MINIMUM HORIZONTAL SEPARATION OF 10 FEET FROM ALL WATER SUPPLY LINES. WHEN A 10 FOOT SEPARATION CANNOT BE MAINTAINED THE WATER MAIN SHALL BE INSTALLED IN A SEPARATE TRENCH ABOVE THE SEWER WITH AN 18 INCH VERTICAL SEPARATION BETWEEN THE CROWN OF THE SEWER AND THE INVERT OF THE WATER MAIN. ADEQUATE VERTICAL SEPARATION OF WATER/SEWER CROSSING SHALL BE CONFIRMED.
 - LOCATION OF EXISTING SEWER SERVICE TO BE DETERMINED AND CUT & CAPPED AT THE MAIN.
 - INTERNAL ROOF DRAIN CONNECTIONS AND LOCATION AND TYPE OF FLOOR DRAINS TO BE COORDINATED WITH PLUMBING CONTRACTOR.
 - SIZE OF FIRE SERVICE LINE TO BE DETERMINED BY FIRE FLOW REQUIREMENTS.
 - CONTRACTOR SHALL CONTACT DIG SAFE AT 1-888-344-7233 72 HOURS PRIOR TO COMMENCING ANY EXCAVATION.
 - CONTRACTOR SHALL FIELD VERIFY DIMENSIONS AND CONDITIONS PRIOR TO THE COMMENCEMENT OF CONSTRUCTION.
 - SHOULD FIELD CONDITIONS VARY FROM THOSE SHOWN, ENGINEER SHALL BE CONTACTED PRIOR TO COMMENCEMENT OF SITE CONSTRUCTION.

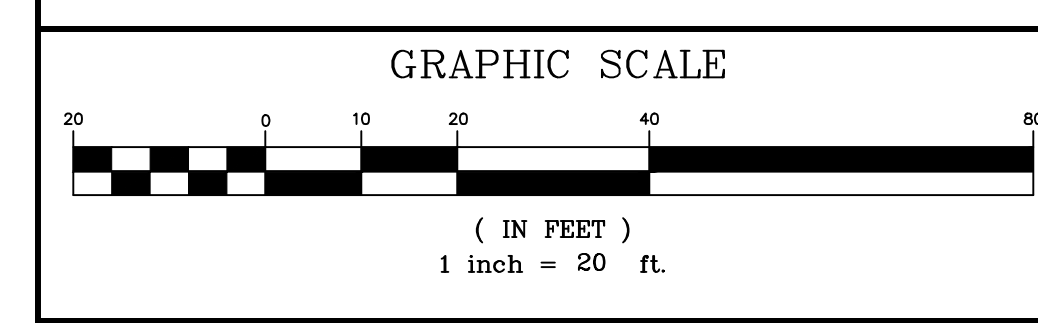

REV. NO.	DATE	REVISION
2	10/30/24	ZBA CONDITIONS OF APPROVAL
1	9/10/24	CITY COMMENTS

TITLE:
DEFINITIVE SITE PLAN
FOR
39 LAMARTINE STREET
WORCESTER, MASSACHUSETTS 01610

PREPARED FOR:
POLAR VIEWS, LLC
89 WEST MAIN STREET UNIT 101
NORTHBOROUGH, MASSACHUSETTS 01532

PROPERTY OWNER:
POLAR VIEWS, LLC
89 WEST MAIN STREET UNIT 101
NORTHBOROUGH, MASSACHUSETTS 01532

PREPARED BY:
J.M. GRENIER ASSOCIATES INC.
118 TURNPIKE ROAD SUITE 200
SOUTHBOROUGH, MASSACHUSETTS 01772
TELE NO.: (508) 845-2500 jmgrenier@townisp.com

SCALE: 1" = 20'
DATE: JUNE 6, 2024

UTILITY PLAN

SHEET NO.: SHEET 5 OF 8
PROJECT NO.: G-647



1. Seeding and repairs shall be performed as required. Sediment and debris shall be removed at least once a year, typically in early spring prior to the commencement of the growing season.

2. The CDS unit shall be inspected and cleaned as recommended by the manufacturer.

3. The pump chamber shall be inspected yearly. Pump maintenance shall follow manufacturer's instructions.

4. The contractor will be responsible for the maintenance of all drainage structures and until such time as the site work is complete. The maintenance will then be the responsibility of the property owners.

STORMWATER COLLECTION & TREATMENT SYSTEM INSPECTION & MAINTENANCE GUIDELINES

- GENERAL:**
- THIS PLAN IS INTENDED TO PROVIDE GUIDANCE AND INSTRUCTION TO THE CITY OF WORCESTER AND THE CONTRACTOR(S) IN THE PREVENTION OF EROSION AND SEDIMENTATION OFF-SITE. THIS PLAN IS INTENDED TO ALLOW ANY CONDITIONS OF APPROVAL TO BE MORE SPECIFIC IN ADDRESSING ITEMS OF CONCERN. IF CONDITIONS BY THE CITY OF WORCESTER ARE IN CONFLICT WITH REQUIREMENTS AS SPECIFIED ON THE PLANS CONDITIONS AS SPECIFIED BY THE CITY OF WORCESTER SHALL SUPERSEDE THE REQUIREMENTS SPECIFIED ON THESE PLANS.
- PRE-CONSTRUCTION:**
- AN EROSION CONTROL BARRIER (SEE BELOW) SHALL BE INSTALLED AS DEPICTED ON THE PLANS, BETWEEN THE AREAS TO BE DISTURBED AND RECEIVING DRAINAGE WAY AND STRUCTURES. THIS BARRIER SHALL REMAIN IN PLACE UNTIL ALL TRIBUTARY SURFACES HAVE BEEN FULLY STABILIZED. THE EROSION CONTROL BARRIERS AS SHOWN ON THE PLANS ARE THE MINIMUM PROTECTIVE MEASURES REQUIRED TO PROTECT THE ON AND OFF-SITE DRAINAGE SYSTEMS.
 - THE CONTRACTOR SHALL ESTABLISH A STAGING AREA AS SHOWN ON THE PLAN FOR THE OVERNIGHT STORAGE OF EQUIPMENT AND STOCKPILING OF MATERIALS.
 - IN THE STAGING AREA, THE CONTRACTOR SHALL HAVE A STOCKPILE OF MATERIALS REQUIRED TO CONTROL EROSION ON-SITE TO BE USED TO SUPPLEMENT OR REPAIR EROSION CONTROL DEVICES. THESE MATERIALS SHALL INCLUDE, BUT ARE NOT LIMITED TO: HAY BALES, SILT FENCE AND CRUSHED STONE.
 - A TEMPORARY STONE CONSTRUCTION ENTRANCE IS REQUIRED TO PREVENT TRACKING OF SILT, MUD, ETC. ONTO EXISTING ROADS. THE STONE SHALL BE REPLACED REGULARLY AS WELL AS WHEN THE STONE IS SILT LOADED OR EQUIPMENT IS OBSERVED TO BE TRACKING SOIL ONTO THE ROADWAYS. SEE GENERAL CONSTRUCTION REQUIREMENTS, SEE NOTE #4 BELOW.
 - THE CONTRACTOR IS RESPONSIBLE FOR EROSION CONTROL ON & OFF-SITE AND SHALL UTILIZE EROSION CONTROL MEASURES WHERE NEEDED, REGARDLESS OF WHETHER THE MEASURES ARE SPECIFIED HEREIN, ON THE PLAN OR IN ANY ORDER OF CONDITIONS.
- PRELIMINARY SITE WORK:**
- MATERIAL REMOVED SHOULD BE STOCKPILED, SEPARATING THE TOPSOIL FOR FUTURE USE ON THE SITE OR IN A SECURED OFF-SITE AREA APPROVED BY THE OWNER. EROSION CONTROLS SHALL BE UTILIZED ALONG THE DOWN-SLOPE OF THE PILES IF THE PILES ARE TO REMAIN FOR MORE THAN THREE WEEKS.
 - IF INTENSE RAINFALL IS ANTICIPATED, THE INSTALLATION OF SUPPLEMENTAL HAY BALES, SILT FENCES, OR ARMORED DIKES SHALL BE UTILIZED.
 - IF THE SITE CONSTRUCTION OCCURS AT ANY TIME OTHER THAN THE APRIL - DECEMBER CONSTRUCTION SEASON, ALL DRAINAGE SYSTEMS TEMPORARY OR PERMANENT SHALL MAINTAIN TO ENSURE ADEQUATE HYDRAULIC CAPACITY, AND DRAINING CHARACTERISTICS.
- EROSION CONTROL MEASURES:**
- THE CONTRACTOR SHALL BE RESPONSIBLE FOR ENSURING THAT EROSION AND SEDIMENTATION ARE CONTROLLED. THIS PLAN SHALL BE ADAPTED TO FIT THE CONTRACTOR'S EQUIPMENT, WEATHER CONDITIONS, AND ANY CONDITIONS ISSUED BY THE CITY OF WORCESTER.
 - THE MOST IMPORTANT ASPECTS OF CONTROLLING EROSION AND SEDIMENTATION ARE LIMITING THE EXTENT OF DISTURBANCE AND STABILIZING SURFACES AS SOON AS POSSIBLE. OF SECONDARY IMPORTANCE IN EROSION CONTROL IS THE LIMITING THE SIZE AND LENGTH OF THE TRIBUTARY DRAINAGE AREA WITHIN THE WORK SITE AND DRAINAGE STRUCTURES. THESE FUNDAMENTAL PRINCIPLES SHALL BE THE KEY FACTOR IN THE CONTRACTOR'S CONTROL OF EROSION ON THE SITE.
 - THE EXISTING SOIL CONDITIONS PROVIDE THE POTENTIAL OF RUNOFF TO OFF-SITE AREAS WITH EROSION POTENTIAL.
 - ALL DISTURBED SURFACES SHALL BE STABILIZED A MINIMUM OF 14 DAYS AFTER CONSTRUCTION IN ANY PORTION OF THE SITE HAS CEASED OR IS TEMPORARILY HALTED UNLESS ADDITIONAL CONSTRUCTION IS INTENDED TO BE INITIATED WITHIN 21 DAYS.
 - THE CONTRACTOR IS RESPONSIBLE FOR THE MAINTENANCE AND REPAIR OF ALL EROSION CONTROL DEVICES WITHIN THE LIMIT OF WORK. ALL EROSION CONTROL DEVICES SHALL BE REGULARLY INSPECTED. ANY SEDIMENTS REMOVED FROM THE CONTROL DEVICES SHALL BE DISPOSED OF.
 - AT NO TIME SHALL SILT-LOADED WATER BE ALLOWED TO ENTER SENSITIVE AREAS (WETLANDS, OFF-SITE AREAS AND DRAINAGE SYSTEMS). ANY RUNOFF FROM DISTURBED SURFACES SHALL BE DIRECTED THROUGH SETTLING BASINS AND EROSION CONTROL BARRIERS PRIOR TO ENTERING ANY SENSITIVE AREAS.
- GENERAL CONSTRUCTION REQUIREMENTS:**
- ANY REFUELING OF CONSTRUCTION VEHICLES AND EQUIPMENT SHALL NOT TAKE PLACE INSIDE OF A 100 FOOT BUFFER ZONE, NEAR THE ENTRANCE TO ANY DRAINAGE SYSTEM AND SHALL NOT BE CONDUCTED IN PROXIMITY TO SEDIMENTATION BASINS.
 - NO ON-SITE DISPOSAL OF STUMPS, SOLID WASTE, INCLUDING CONSTRUCTION MATERIALS IS ALLOWED.
 - NO MATERIALS SHALL BE DISPOSED OF INTO THE WETLANDS, OR EXISTING/PROPOSED DRAINAGE SYSTEMS. ALL CONTRACTORS INCLUDING CONCRETE SUPPLIERS, PAINTERS AND PLASTERERS, SHALL BE INFORMED THAT THE CLEANING OF EQUIPMENT IS PROHIBITED IN AREAS WHERE THE WASH-WATER WILL DRAIN DIRECTLY TO THE SITE DRAINAGE SYSTEMS.
 - THE CONTRACTOR SHALL UNDERTAKE ALL WORK TO LIMIT AIRBORNE SEDIMENTS, ONLY CLEAN, POTABLE WATER MAY BE USED TO CONTROL DUST.
- LANDSCAPING:**
- LANDSCAPING SHALL OCCUR AS SOON AS POSSIBLE TO PROVIDE PERMANENT STABILIZATION OF DISTURBED SURFACES.
 - CONTRACTOR SHALL UTILIZE A VARIETY OF SLOPE STABILIZATION METHODS AND MATERIALS WHICH SHALL BE ADJUSTED TO THE SITE CONDITIONS. EROSION CONTROL BLANKETS OR MIRAFI MIRAMAT (OR SIMILAR PRODUCTS) SHALL BE AVAILABLE ON SITE.
 - IF THE SEASON OR ADVERSE WEATHER CONDITIONS DO NOT ALLOW THE ESTABLISHMENT OF VEGETATION, TEMPORARY MULCHING WITH HAY, TACKIFIED WOOD CHIPS OR OTHER METHODS SHALL BE PROVIDED.
 - ALL DISTURBED SURFACES TO BE PLANTED SHALL RECEIVE A MINIMUM OF 6" TOPSOIL SHALL BE PLACED AND ITS SURFACE SMOOTHED TO THE SPECIFIED GRADES.
 - ALL SLOPES OF 2.5:1 OR GREATER SHALL BE STABILIZED WITH EROSION CONTROL FABRIC.
 - TO ENSURE A DENSE, SUCCESSION GROWTH, SEED IS REQUIRED ON ALL DISTURBED SURFACES.

- LEGEND:**
- EXISTING PROPERTY LINE
 - EXISTING EASEMENT LINE
 - 450- EXISTING CONTOUR - HIGH
 - 448- EXISTING CONTOUR - LOW
 - 450- PROPOSED CONTOUR - HIGH
 - 448- PROPOSED CONTOUR - LOW
 - EXISTING EDGE PAVEMENT
 - EXISTING CURB
 - PROPOSED EDGE OF PAVEMENT
 - PROPOSED CURB
 - D --- EXISTING DRAIN LINE
 - D --- PROPOSED DRAIN LINE
 - FM --- PROPOSED FORCE MAIN
 - W --- EXISTING WATER LINE
 - W --- PROPOSED WATER LINE
 - S --- EXISTING SEWER LINE
 - S --- PROPOSED SEWER LINE
 - G --- EXISTING GAS LINE
 - E --- EXISTING UNDERGROUND ELECTRIC
 - C --- EXISTING UNDERGROUND CABLE TV
 - PROPOSED EROSION CONTROL

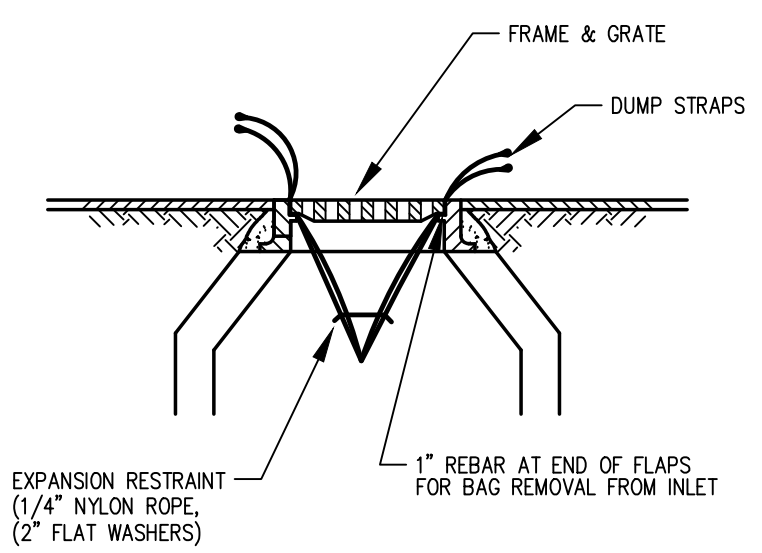

NOTE:
BAGS SHOULD BE CLEANED OUT AFTER EVERY RAIN EVENT AND/OR AS NEEDED.

SILT SACK DETAIL
NOT TO SCALE

CONSTRUCTION SEQUENCING:

- SELECTIVELY CUT TREES AND CLEAR BRUSH TO BE CHIPPED AND HAULED OFF SITE. NOTE THAT THE SITE IS IN THE ASIAN LONGHORNED BEETLE (ALB) REGULATED AREA.
 - STAKE LOCATION OF AND INSTALL EROSION CONTROL BARRIER, CONSTRUCTION ENTRANCE AS DELINEATED ON SITE PLAN.
 - STRIP TOP AND SUBSOIL AS NECESSARY IN WORK AREA. STOCKPILE MATERIAL ON SOUTH PORTION OF LOT FOR BACKFILLING PURPOSES AT COMPLETION OF FOUNDATION CONSTRUCTION.
 - FORM AND POUR FOUNDATION FOR NEW BUILDING.
 - BACKFILL FOUNDATION AREAS AS NECESSARY.
 - CONSTRUCT BUILDING.
 - CONSTRUCT DRIVEWAYS AND LOAM AND SEED DISTURBED AREAS.
 - ALL EXCESS MATERIALS TO BE REMOVED FROM THE SITE AS SOON AS PRACTICAL.
 - ALL GRADED AREAS TO BE LANDSCAPED, LOAMED AND SEED AS SOON AS PRACTICAL TO REDUCE ANY POTENTIAL EROSION.
- NOTE:** PROCESSES AS DESCRIBED ABOVE ARE ESTIMATED TO TAKE 9 MONTHS. WINTER CONDITIONS MAY AFFECT THIS SCHEDULE.

- GENERAL CONSTRUCTION REQUIREMENTS:**
- ANY REFUELING OF CONSTRUCTION VEHICLES AND EQUIPMENT SHALL NOT TAKE PLACE INSIDE OF A 100 FOOT BUFFER ZONE, NEAR THE ENTRANCE TO ANY DRAINAGE SYSTEM AND SHALL NOT BE CONDUCTED IN PROXIMITY TO SEDIMENTATION BASINS.
 - NO ON-SITE DISPOSAL OF STUMPS, SOLID WASTE, INCLUDING CONSTRUCTION MATERIALS IS ALLOWED.
 - NO MATERIALS SHALL BE DISPOSED OF INTO THE WETLANDS, OR EXISTING/PROPOSED DRAINAGE SYSTEMS. ALL CONTRACTORS INCLUDING CONCRETE SUPPLIERS, PAINTERS AND PLASTERERS, SHALL BE INFORMED THAT THE CLEANING OF EQUIPMENT IS PROHIBITED IN AREAS WHERE THE WASH-WATER WILL DRAIN DIRECTLY TO THE SITE DRAINAGE SYSTEMS.
 - THE CONTRACTOR SHALL UNDERTAKE ALL WORK TO LIMIT AIRBORNE SEDIMENTS, ONLY CLEAN, POTABLE WATER MAY BE USED TO CONTROL DUST.
- LANDSCAPING:**
- LANDSCAPING SHALL OCCUR AS SOON AS POSSIBLE TO PROVIDE PERMANENT STABILIZATION OF DISTURBED SURFACES.
 - CONTRACTOR SHALL UTILIZE A VARIETY OF SLOPE STABILIZATION METHODS AND MATERIALS WHICH SHALL BE ADJUSTED TO THE SITE CONDITIONS. EROSION CONTROL BLANKETS OR MIRAFI MIRAMAT (OR SIMILAR PRODUCTS) SHALL BE AVAILABLE ON SITE.
 - IF THE SEASON OR ADVERSE WEATHER CONDITIONS DO NOT ALLOW THE ESTABLISHMENT OF VEGETATION, TEMPORARY MULCHING WITH HAY, TACKIFIED WOOD CHIPS OR OTHER METHODS SHALL BE PROVIDED.
 - ALL DISTURBED SURFACES TO BE PLANTED SHALL RECEIVE A MINIMUM OF 6" TOPSOIL SHALL BE PLACED AND ITS SURFACE SMOOTHED TO THE SPECIFIED GRADES.
 - ALL SLOPES OF 2.5:1 OR GREATER SHALL BE STABILIZED WITH EROSION CONTROL FABRIC.
 - TO ENSURE A DENSE, SUCCESSION GROWTH, SEED IS REQUIRED ON ALL DISTURBED SURFACES.

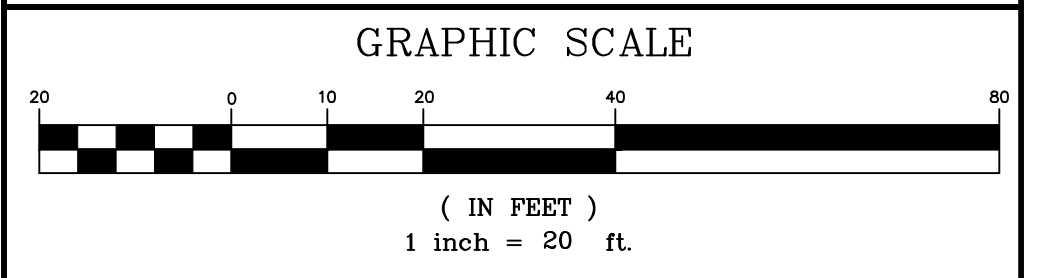

2	10/30/24	ZBA CONDITIONS OF APPROVAL
1	9/10/24	CITY COMMENTS
REV. NO.	DATE	REVISION

TITLE:

DEFINITIVE SITE PLAN FOR 39 LAMARTINE STREET WORCESTER, MASSACHUSETTS 01610

PREPARED FOR:

**POLAR VIEWS, LLC
89 WEST MAIN STREET UNIT 101
NORTHBOROUGH, MASSACHUSETTS 01532**

PROPERTY OWNER:

**POLAR VIEWS, LLC
89 WEST MAIN STREET UNIT 101
NORTHBOROUGH, MASSACHUSETTS 01532**

PREPARED BY:

**J.M. GRENIER ASSOCIATES INC.
118 TURNPIKE ROAD SUITE 200
SOUTHBOROUGH, MASSACHUSETTS 01772**

TELE. NO.: (508) 845-2500 jmgrenier@townisp.com

SCALE: 1" = 20' **DATE:** JUNE 6, 2024

EROSION & SEDIMENTATION CONTROL PLAN

SHEET NO.: SHEET 6 OF 8 **PROJECT NO.:** G-647

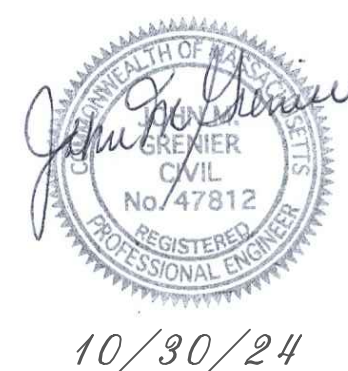
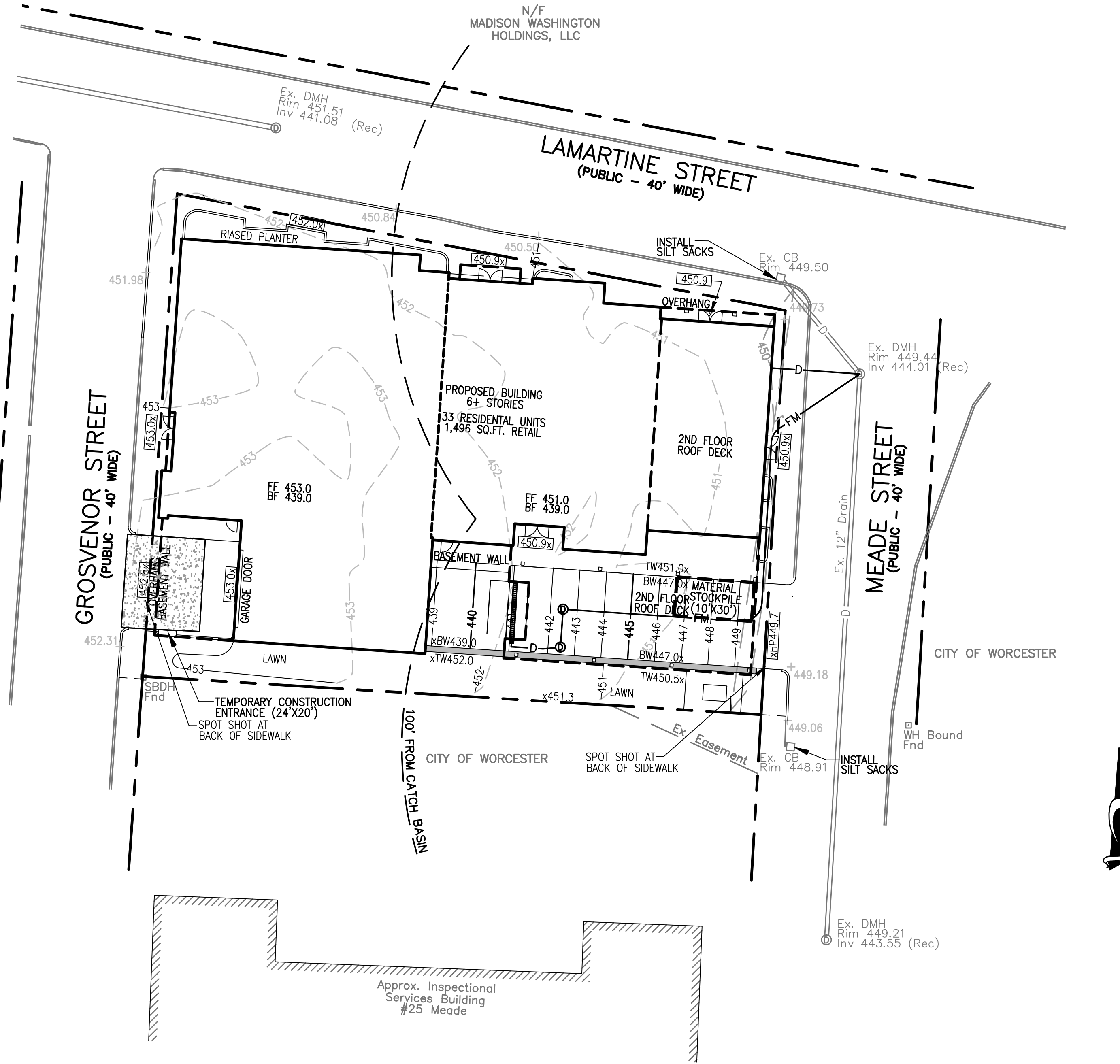
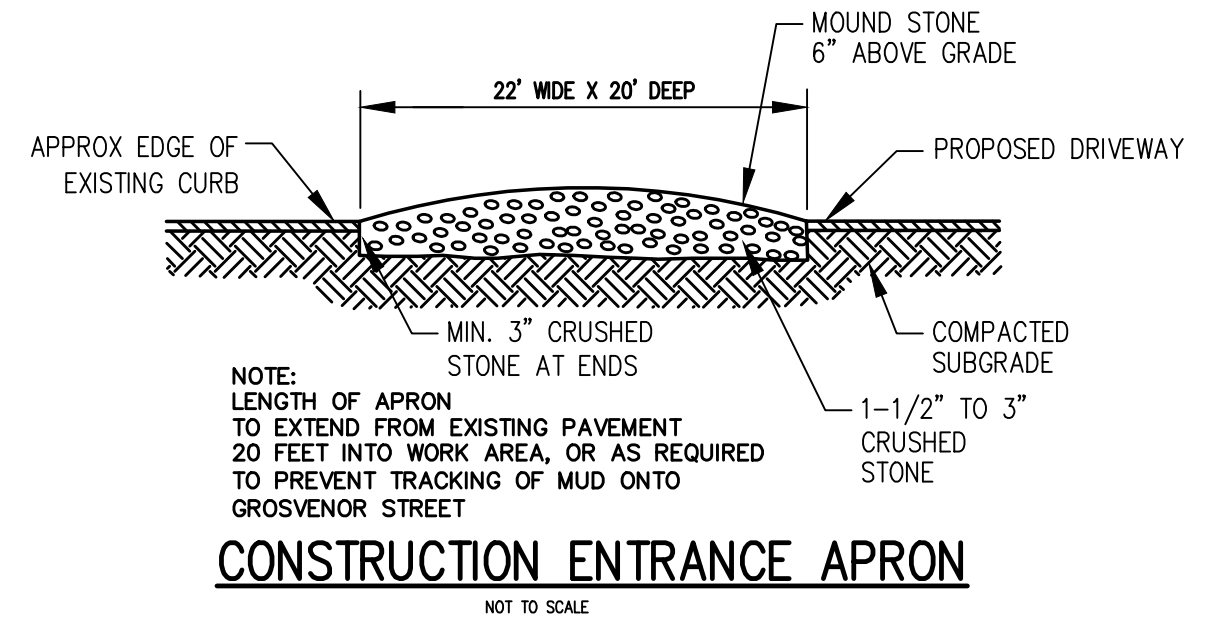

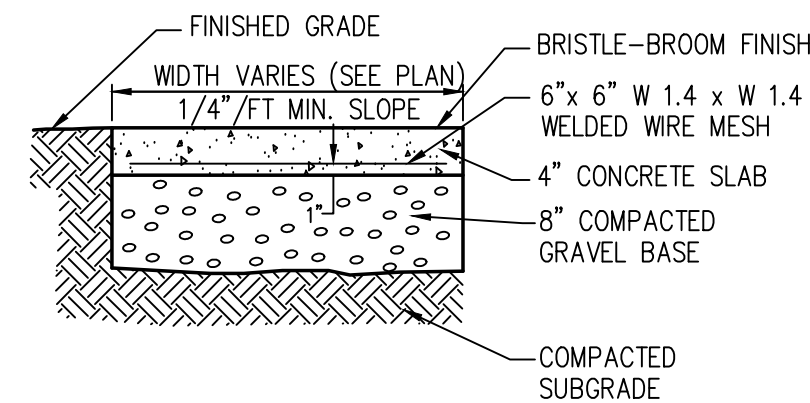

CEMENT CONCRETE PAVEMENT/WALK
NOT TO SCALE

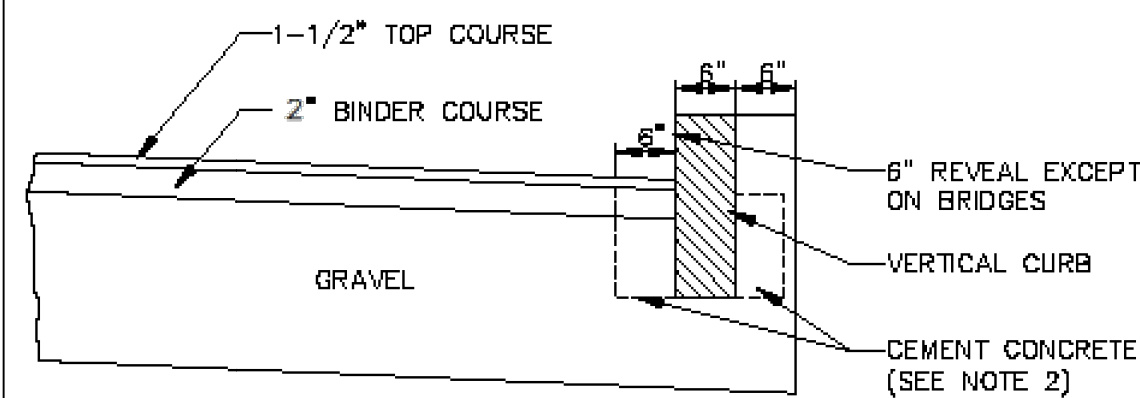

- NOTES:**
- CUT NEAR LINE 6" FROM CURB LINE AND REMOVE BINDER, BASE AND STONE, REPLACE WITH CEMENT CONCRETE.
 - ANY CLASS CEMENT CONCRETE THAT IS ACCEPTABLE TO THE DEPARTMENT UNDER SECTION M4 OF THE 1973 STANDARD SPECIFICATIONS. ALL TEST REQUIREMENTS ARE WAIVED. BITUMINOUS CONCRETE SHALL NOT BE USED AS A SUBSTITUTE.
 - PAYMENT FOR CLASS B CONCRETE WILL BE PAID FOR UNDER ITEM 446.1.

VERTICAL GRANITE CURB
NOT TO SCALE

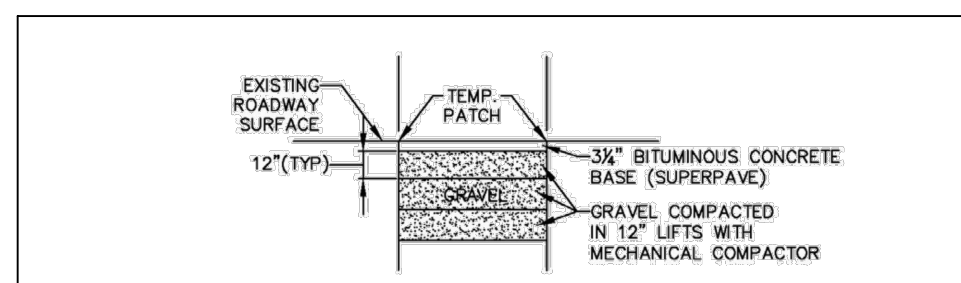

TEMPORARY PATCH

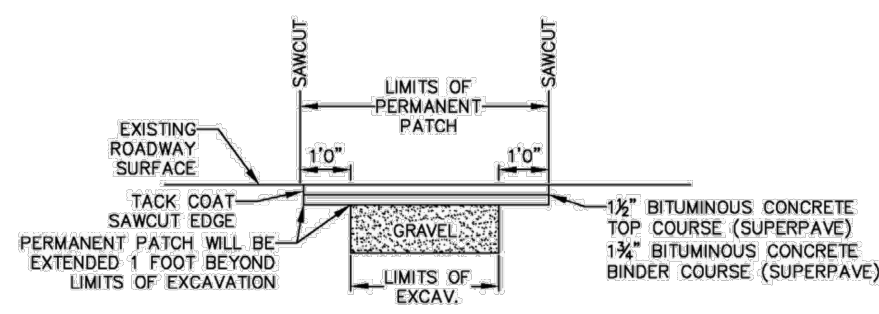

NOTE: PERMANENT PATCH FOR ROADS HAVING A PAVING BLOCK OR CONCRETE BASE SHALL INCLUDE A LAYER OF CONCRETE EQUAL TO THE DEPTH OF THE EXISTING CONCRETE OR PAVING BLOCK. IN SUCH CASES THE DEPTH OF THE GRAVEL BACKFILL SHALL NOT BE LESS THAN 12 INCHES.

PERMANENT PATCH

PAVEMENT REPAIR
NOT TO SCALE

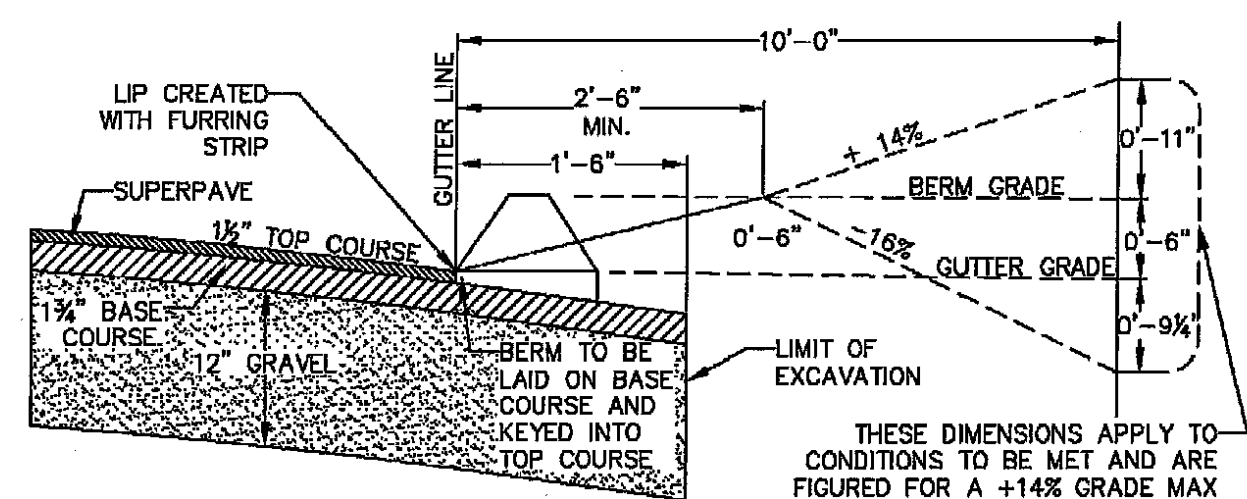
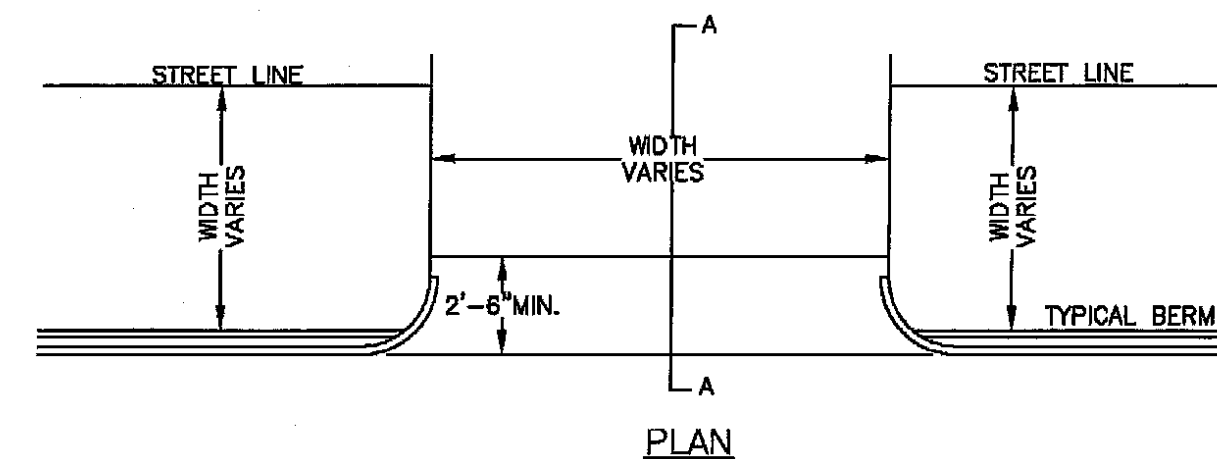

SECTION A-A
NOT TO SCALE

DRIVEWAY DETAIL
NOT TO SCALE

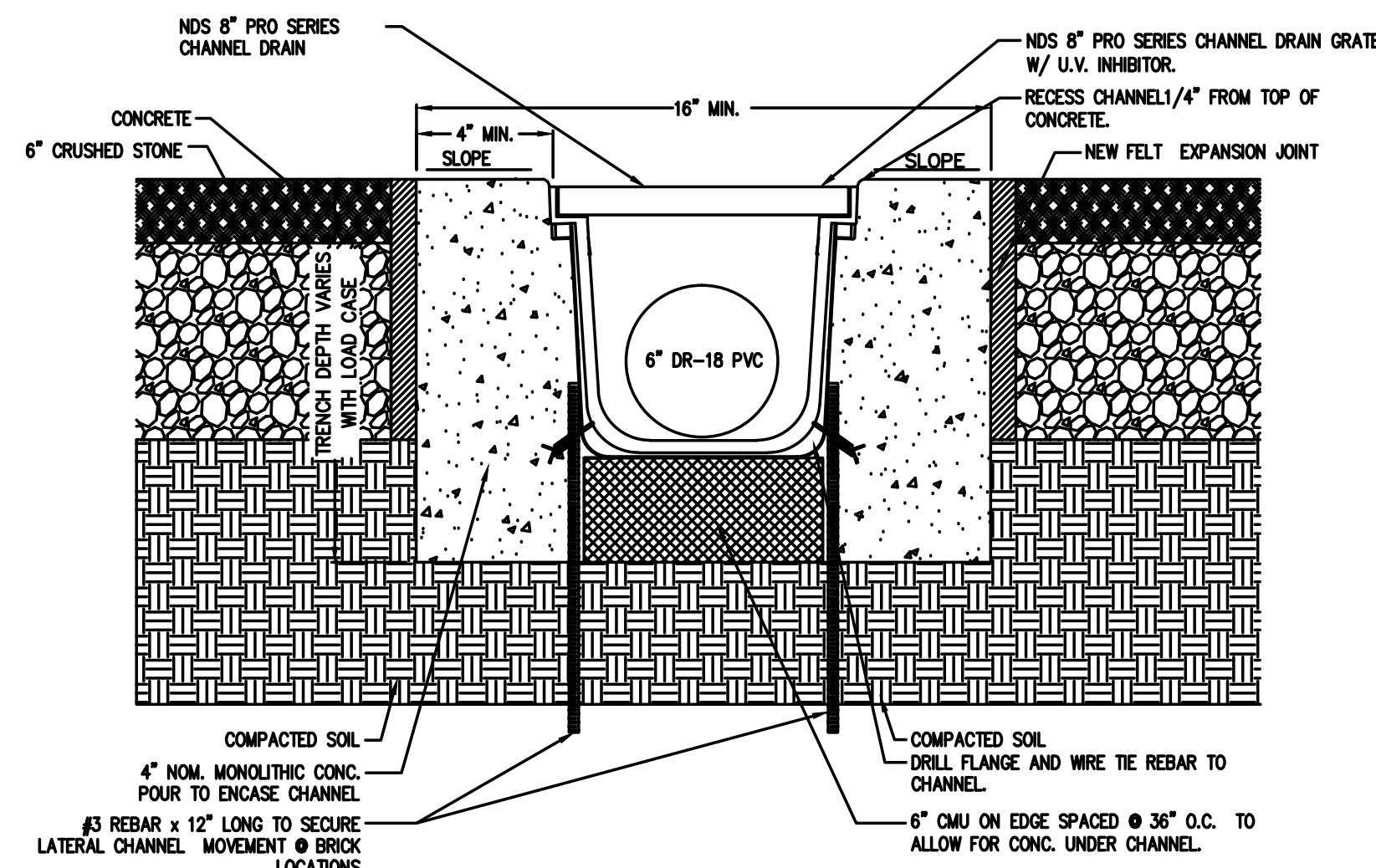

TRENCH DRAIN CROSS-SECTION
NOT TO SCALE

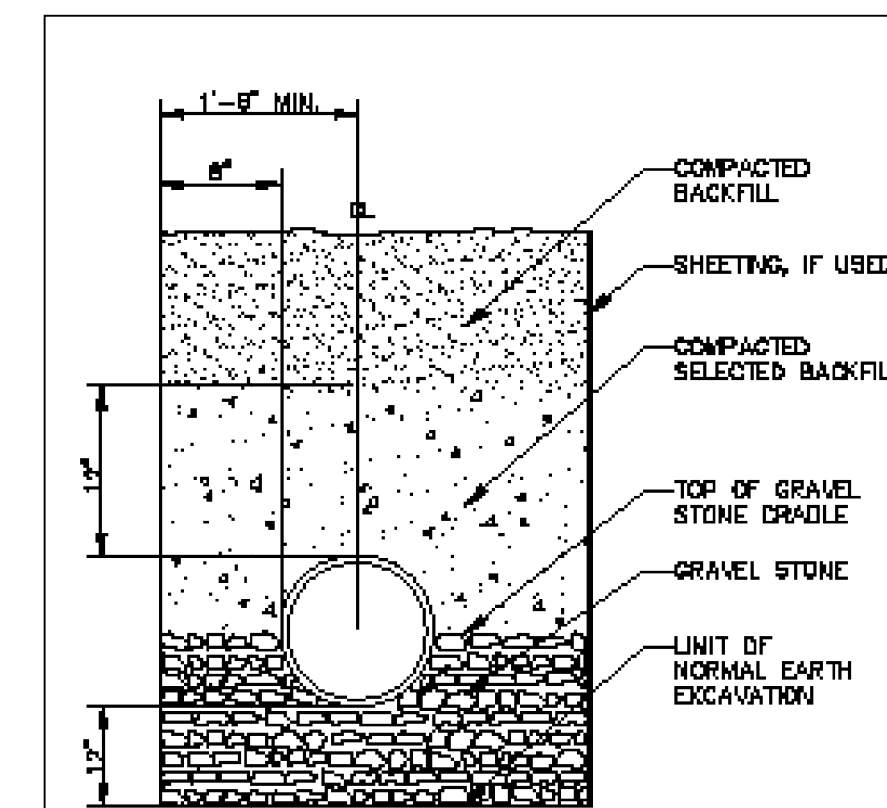

DRAIN TRENCH DETAIL
NOT TO SCALE

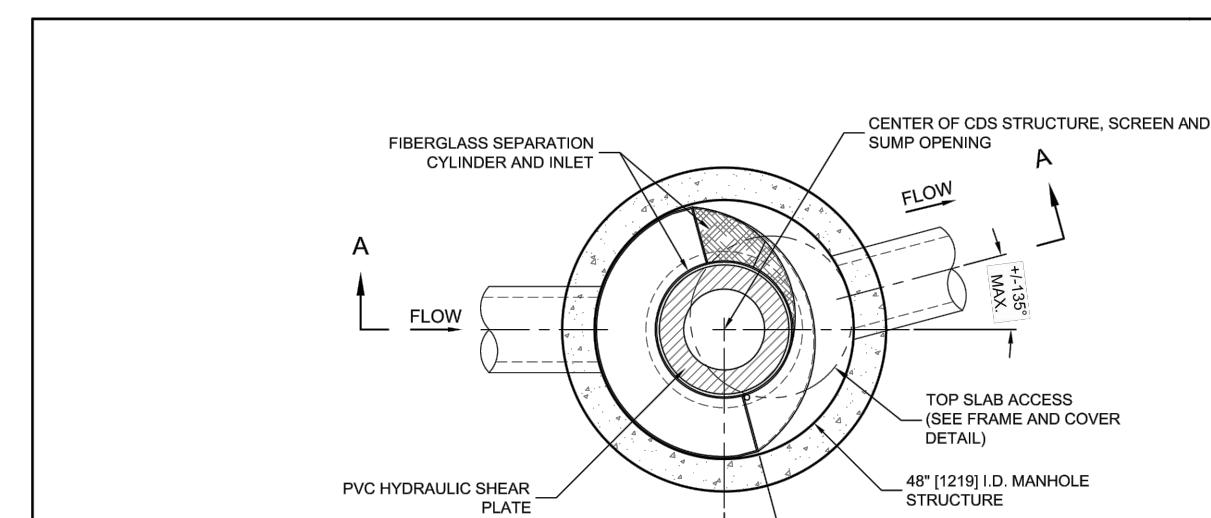

PLAN VIEW B-B
N.T.S.

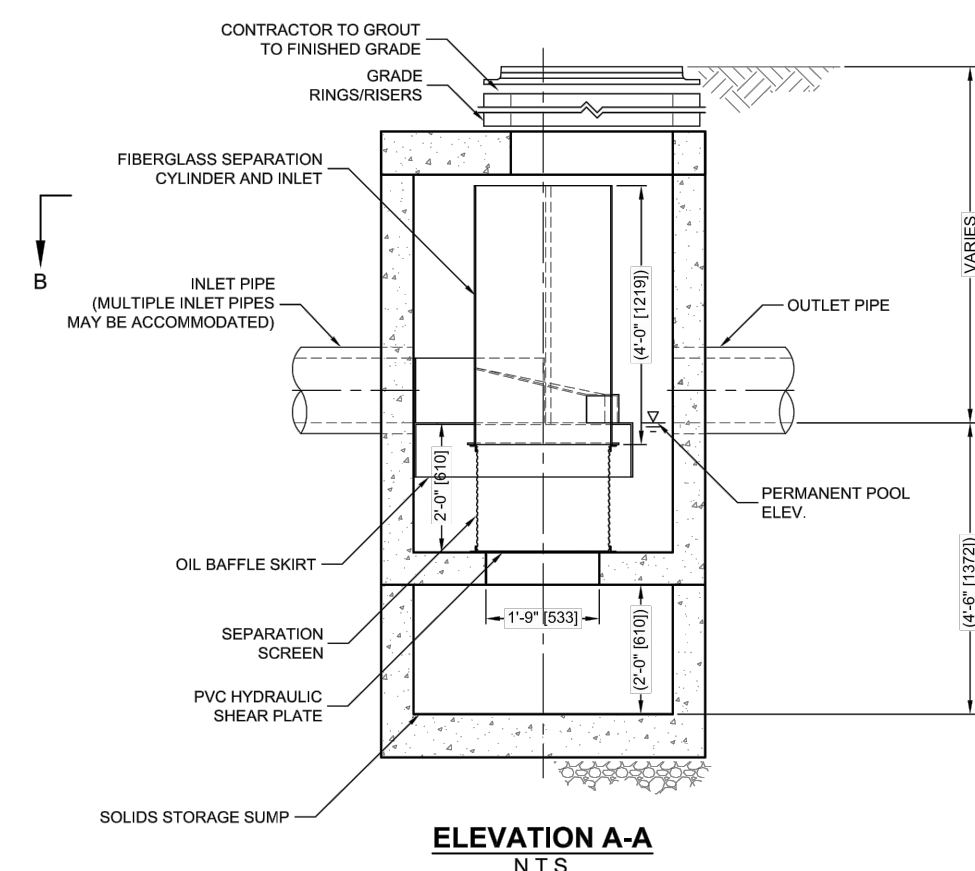

ELEVATION A-A
N.T.S.

CDS2015-4-C DESIGN NOTES

THE STANDARD CDS2015-4-C CONFIGURATION IS SHOWN. ALTERNATE CONFIGURATIONS ARE AVAILABLE AND ARE LISTED BELOW. SOME CONFIGURATIONS MAY BE COMBINED TO SUIT SITE REQUIREMENTS.

CONFIGURATION DESCRIPTION
GRATED INLET ONLY (NO INLET PIPE)
GRATED INLET WITH INLET PIPE OR PIPES
CURB INLET ONLY (NO INLET PIPE)
CURB INLET WITH INLET PIPE OR PIPES
SEPARATE OIL BAFFLE (SINGLE INLET PIPE REQUIRED FOR THIS CONFIGURATION)
SEDIMENT WEIR FOR NUPEC / NUCAT CONFORMING UNITS

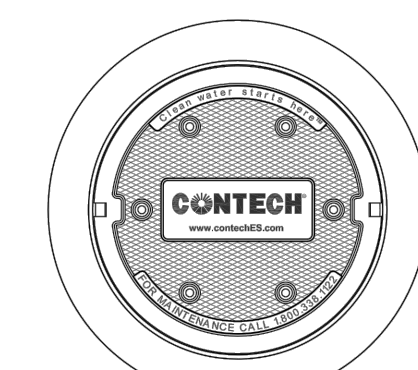

FRAME AND COVER
DIAMETER VARIES
N.T.S.

SITE SPECIFIC DATA REQUIREMENTS

STRUCTURE ID	WATER QUALITY FLOW RATE (CFS OR L/s)	PEAK FLOW RATE (CFS OR L/s)	RETURN PERIOD OF PEAK FLOW (YRS)	SCREEN APERTURE (2400 OR 4700)

PIPE DATA	I.E.	MATERIAL	DIAMETER
INLET PIPE 1			
INLET PIPE 2			
OUTLET PIPE			

ANTI-FLOTATION BALLAST	WIDTH	HEIGHT

NOTES/SPECIAL REQUIREMENTS:

PER ENGINEER OF RECORD

- GENERAL NOTES**
- CONTRACTOR TO PROVIDE ALL MATERIALS UNLESS NOTED OTHERWISE.
 - DIMENSIONS MARKED WITH (I) ARE REFERENCE DIMENSIONS. ACTUAL DIMENSIONS MAY VARY.
 - FOR FABRICATION DRAWINGS WITH DETAILED STRUCTURE DIMENSIONS AND WEIGHTS, PLEASE CONTACT YOUR CONTECH ENGINEERED SOLUTIONS LLC REPRESENTATIVE. www.contechES.com
 - CDS WATER QUALITY STRUCTURE SHALL BE IN ACCORDANCE WITH ALL DESIGN DATA AND INFORMATION CONTAINED IN THIS DRAWING.
 - STRUCTURE SHALL MEET AASHTO H20 AND CASTINGS SHALL MEET H20 (AASHTO M 306) LOAD RATING, ASSUMING GROUNDWATER ELEVATION AT OR BELOW THE OUTLET PIPE INVERT ELEVATION. ENGINEER OF RECORD TO CONFIRM ACTUAL GROUNDWATER ELEVATION.
 - PVC HYDRAULIC SHEAR PLATE IS PLACED ON SHELF AT BOTTOM OF SCREEN CYLINDER. REMOVE AND REPLACE AS NECESSARY DURING MAINTENANCE CLEANING.
- INSTALLATION NOTES**
- ANY SUBBASE, BACKFILL DEPTH, AND/OR ANTI-FLOTATION PROVISIONS ARE SITE-SPECIFIC DESIGN CONSIDERATIONS AND SHALL BE SPECIFIED BY ENGINEER OF RECORD.
 - CONTRACTOR TO PROVIDE EQUIPMENT WITH SUFFICIENT LIFTING AND REACH CAPACITY TO LIFT AND SET THE CDS MANHOLE STRUCTURE (LIFTING CLUTCHES PROVIDED).
 - CONTRACTOR TO ADD JOINT SEALANT BETWEEN ALL STRUCTURE SECTIONS, AND ASSEMBLE STRUCTURE.
 - CONTRACTOR TO PROVIDE, INSTALL, AND GROUT PIPES. MATCH PIPE INVERTS WITH ELEVATIONS SHOWN.
 - CONTRACTOR TO TAKE APPROPRIATE MEASURES TO ASSURE UNIT IS WATER TIGHT, HOLDING WATER TO FLOWLINE INVERT MINIMUM. IT IS SUGGESTED THAT ALL JOINTS BELOW PIPE INVERTS ARE GROUTED.

CONTECH
ENGINEERED SOLUTIONS LLC
www.contechES.com
9025 Centre Pointe Dr., Suite 400, West Chester, OH 45399
800-338-1122 613-645-7000 613-645-7801 FAX

CDS2015-4-C
INLINE CDS
STANDARD DETAIL

CDS UNIT DETAIL
NOT TO SCALE

2	10/30/24	ZBA CONDITIONS OF APPROVAL
1	9/10/24	CITY COMMENTS
REV. NO.	DATE	REVISION
TITLE:		
DEFINITIVE SITE PLAN FOR 39 LAMARTINE STREET WORCESTER, MASSACHUSETTS 01610		
PREPARED FOR:		
POLAR VIEWS, LLC 89 WEST MAIN STREET UNIT 101 NORTHBOROUGH, MASSACHUSETTS 01532		
PROPERTY OWNER:		
POLAR VIEWS, LLC 89 WEST MAIN STREET UNIT 101 NORTHBOROUGH, MASSACHUSETTS 01532		
PREPARED BY:		
J.M. GRENIER ASSOCIATES INC. 118 TURNPIKE ROAD SUITE 200 SOUTHBOROUGH, MASSACHUSETTS 01772		
TELE NO.: (508) 845-2500 jmgrenier@townisp.com		
SCALE:	DATE:	
AS SHOWN	JUNE 6, 2024	
DETAIL PLAN 1/2		
SHEET NO.:	PROJECT NO.:	
SHEET 7 OF 8	G-647	



10/30/24

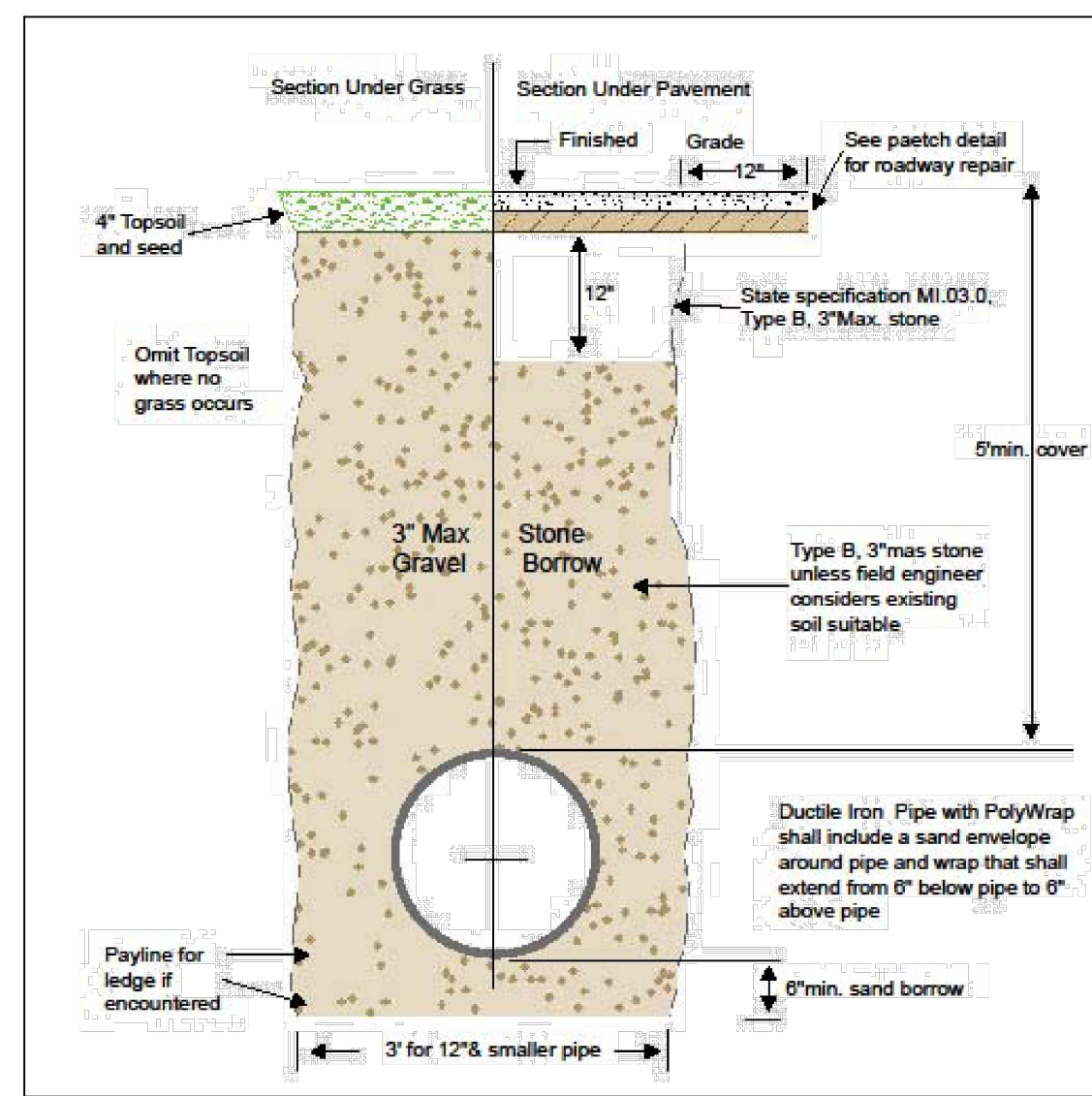

TYPICAL WATER TRENCH SECTION
NOT TO SCALE

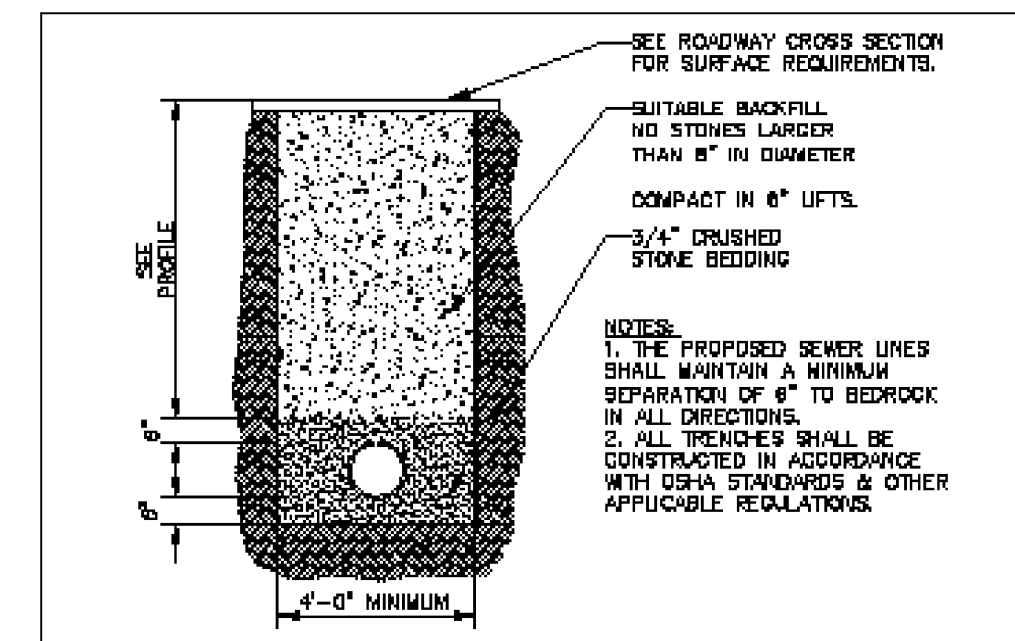

SEWER TRENCH DETAIL
NOT TO SCALE

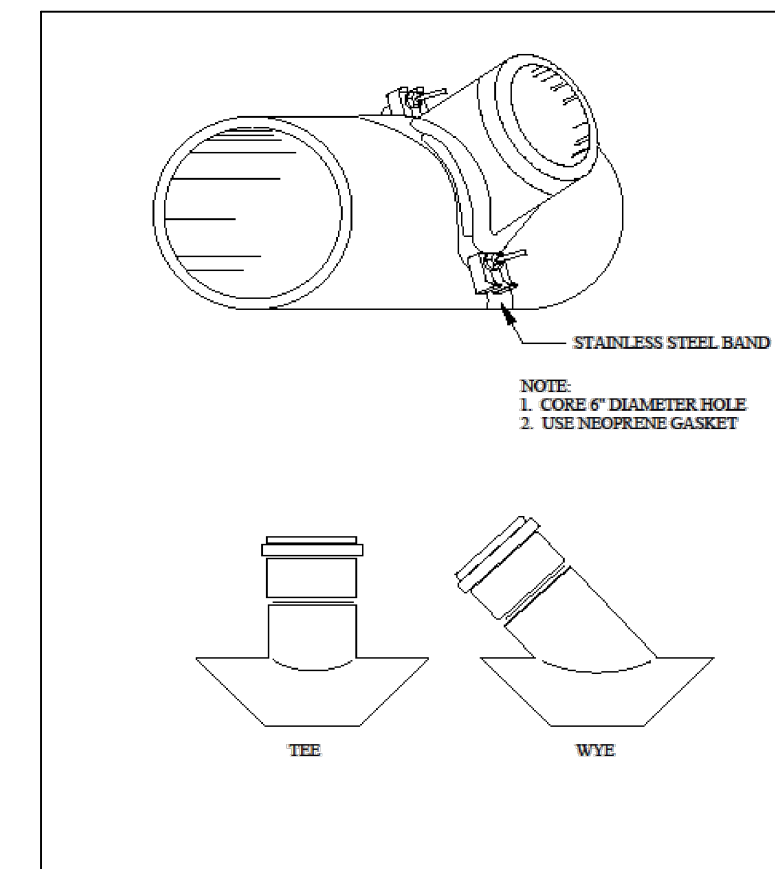

SEWER TEE & WYE CONNECTION
NOT TO SCALE

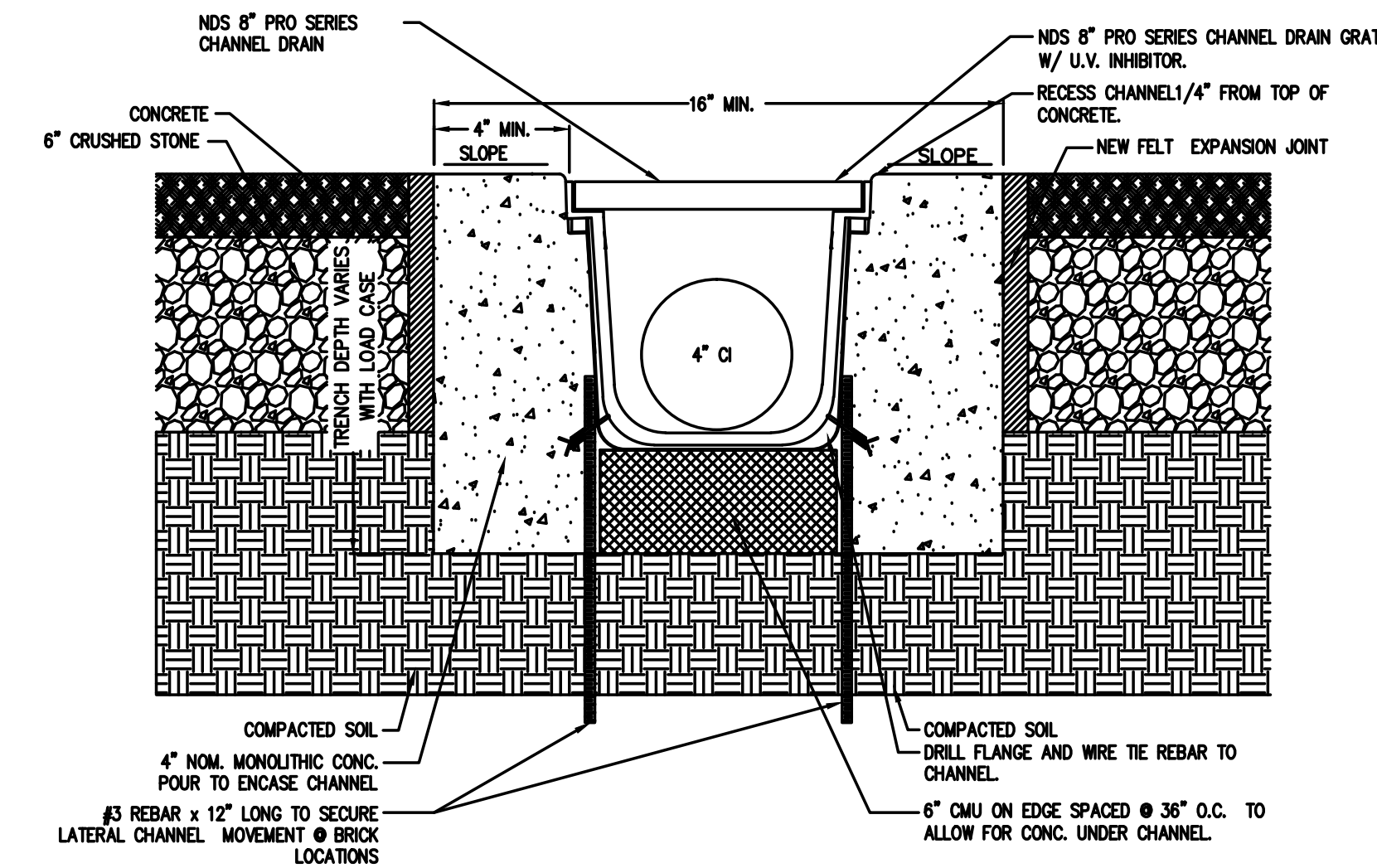

FLOOR DRAIN CROSS-SECTION
NOT TO SCALE

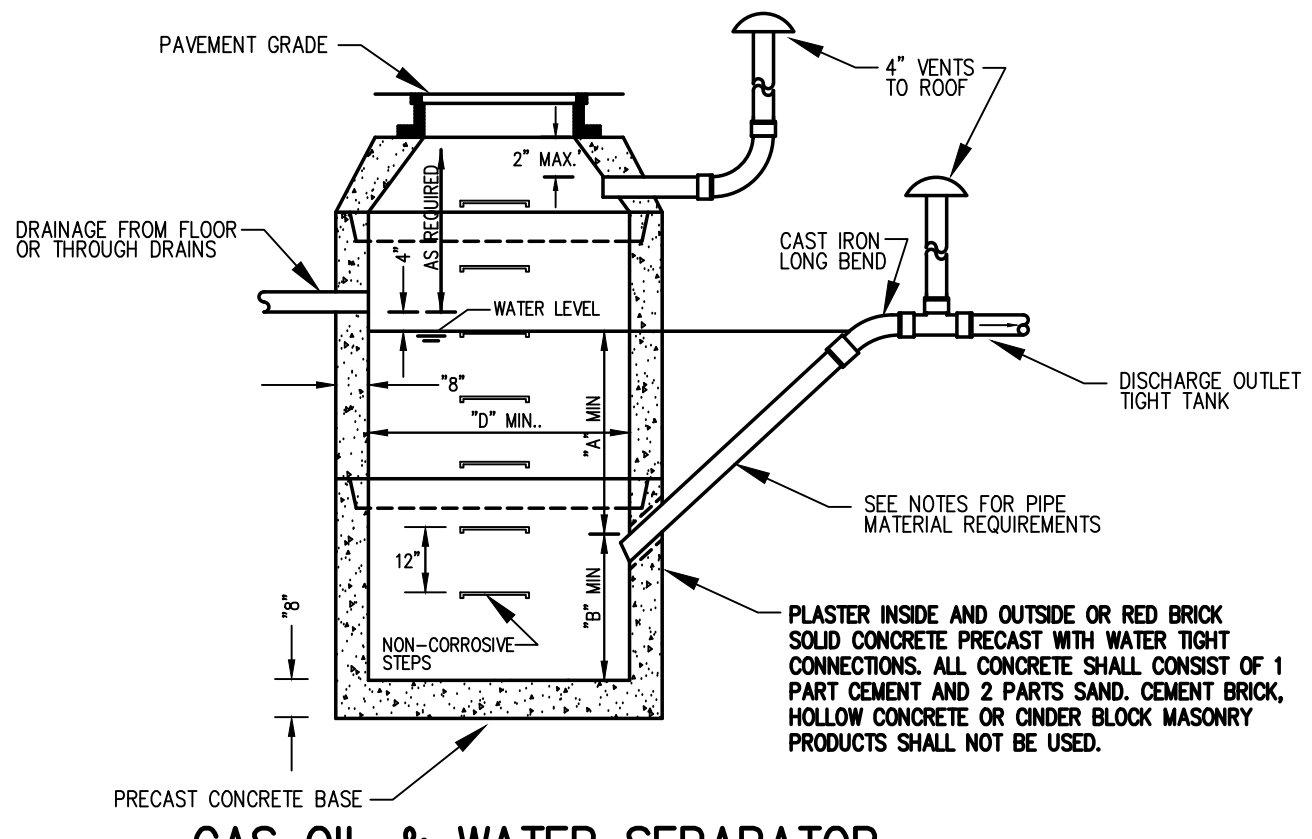

GAS OIL & WATER SEPARATOR
NOT TO SCALE

PIPE MATERIAL NOTES:

- NO-HUB CAST IRON WITH PRODUCT-APPROVED STAINLESS STEEL CLAMPS.
- SERVICE WEIGHT CAST IRON WITH PRODUCT-APPROVED RESILIENT GASKETS OR LEAD AND OAKUM JOINTS.
- EXTRA HEAVY CAST IRON WITH PRODUCT APPROVED RESILIENT GASKETS OR LEAD AND OAKUM JOINTS.

SIZING TABLE

INLET	D	A	B
4"	3'-6"	3'-0"	2'-6"
5"	3'-6"	5'-0"	4'-0"
	3'-6"x3'-6"	4'-0"	3'-0"
	4'-0"	3'-6"	3'-0"
	3'-6"x3'-6"	3'-0"	2'-6"
	4'-6"	3'-0"	2'-6"
6"	4'-0"	5'-0"	4'-6"
	4'-0"x4'-0"	4'-0"	3'-6"
	4'-6"x4'-6"	4'-0"	3'-6"
	5'-0"	3'-6"	3'-0"
	5'-0"x5'-0"	3'-0"	2'-6"
8"	5'-0"	6'-0"	5'-0"
	5'-6"x5'-6"	4'-6"	4'-0"
	6'-0"	4'-0"	3'-6"
	6'-0"x6'-0"	3'-0"	2'-6"
	6'-6"	3'-6"	3'-0"
	6'-6"x6'-6"	3'-0"	2'-6"

GENERAL CONSTRUCTION NOTES:

- THE SEPARATOR IS TO BE LOCATED OUTSIDE OF A BUILDING WHERE POSSIBLE AND THE COVER TO INCORPORATE A CENTER HOLE. A SEALED TIGHT COVER IS TO BE USED IF THE SEPARATOR IS LOCATED INSIDE OF A BUILDING. THE COVER SHALL BE NO LESS THAN A 24" DIAMETER. THE SEPARATOR SHALL BE LOCATED AND CONSTRUCTED TO PREVENT SURFACE OR SUB-SURFACE WATER FROM ENTERING THE INLET PIPE. SHALL BE NO LESS THAN FOUR INCHES ABOVE THE WATER LEVEL. WHEN THE SEPARATOR IS SUBJECT TO FREEZING IT SHALL BE SET A MINIMUM OF THREE FEET BELOW GRADE. THE NON-CORROSIVE STEPS SHALL BE PLACED AT 18" APART. THE CHAMBER VENT AND OUTLET VENT SHALL RETURN TO THE INSIDE OF THE BUILDING AND EXTEND THROUGH THE ROOF.
- IN OPEN PARKING GARAGES OR OPEN PARKING AREAS ONLY THE INLET PIPE MAY EXTEND BELOW THE WATER LINE A MAXIMUM DISTANCE OF 6".
- CIRCULAR BASINS ARE RECOMMENDED.

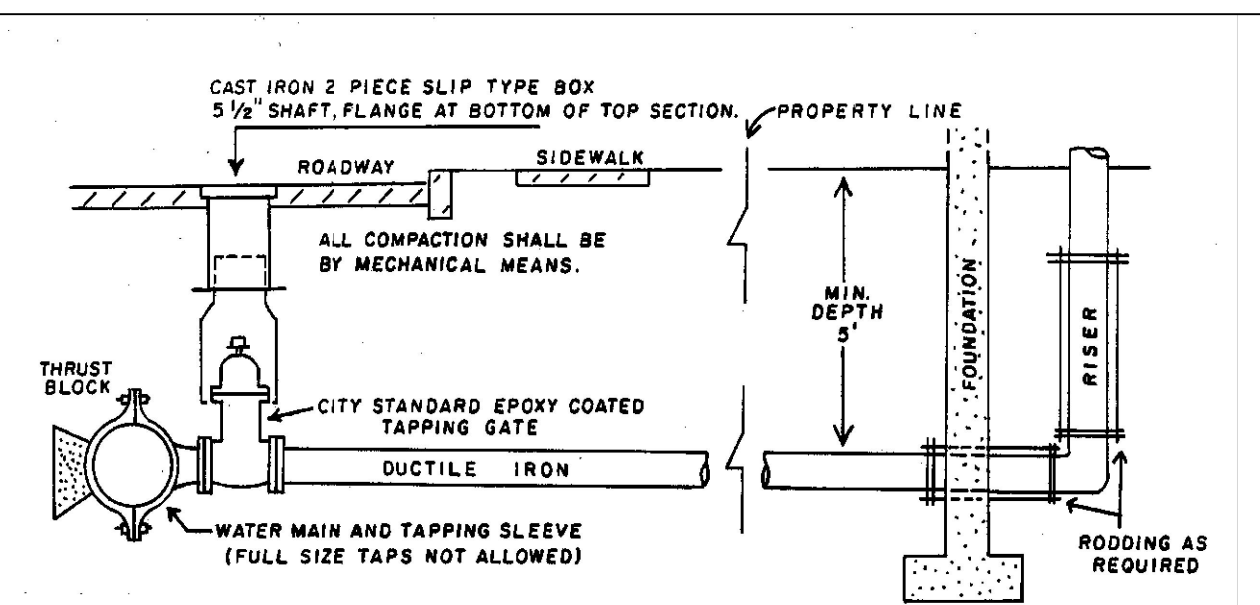

WATER SERVICE DETAIL
NOT TO SCALE

GENERAL NOTES

- Tapping sleeve shall be cast or ductile iron mechanical joint type. Tapping gate to be City Standard Epoxy Coated. The operating nut shall be 2 inches square and shall open right.
- If excavated material is not suitable for backfilling, then the Contractor shall backfill with Gravel Borrow. Material used for backfilling shall contain no stones larger than 3 inches in its greatest dimension.
- Before any excavation is done, a Street Opening Permit shall be obtained from the Public Works office at 20 East Worcester Street. All paving shall conform to City of Worcester D.P.W. standards.
- Main line valves are to be operated by the City only. Costs incurred in shutting down mains due to the negligence of the Contractor as determined by the Field Inspector shall be paid by the Contractor. All tapping sleeves and tapping valve assemblies shall be hydrostatically pressure tested prior to tapping. The test shall be at 1-1/2 times the working pressure of the existing main or a minimum of 150 psi and shall be maintained for two hours, or as directed by the Field Engineer.
- Upon installation of the gate box, the Contractor shall operate the tapping gate to the satisfaction of the Field Inspector prior to acceptance of the job.

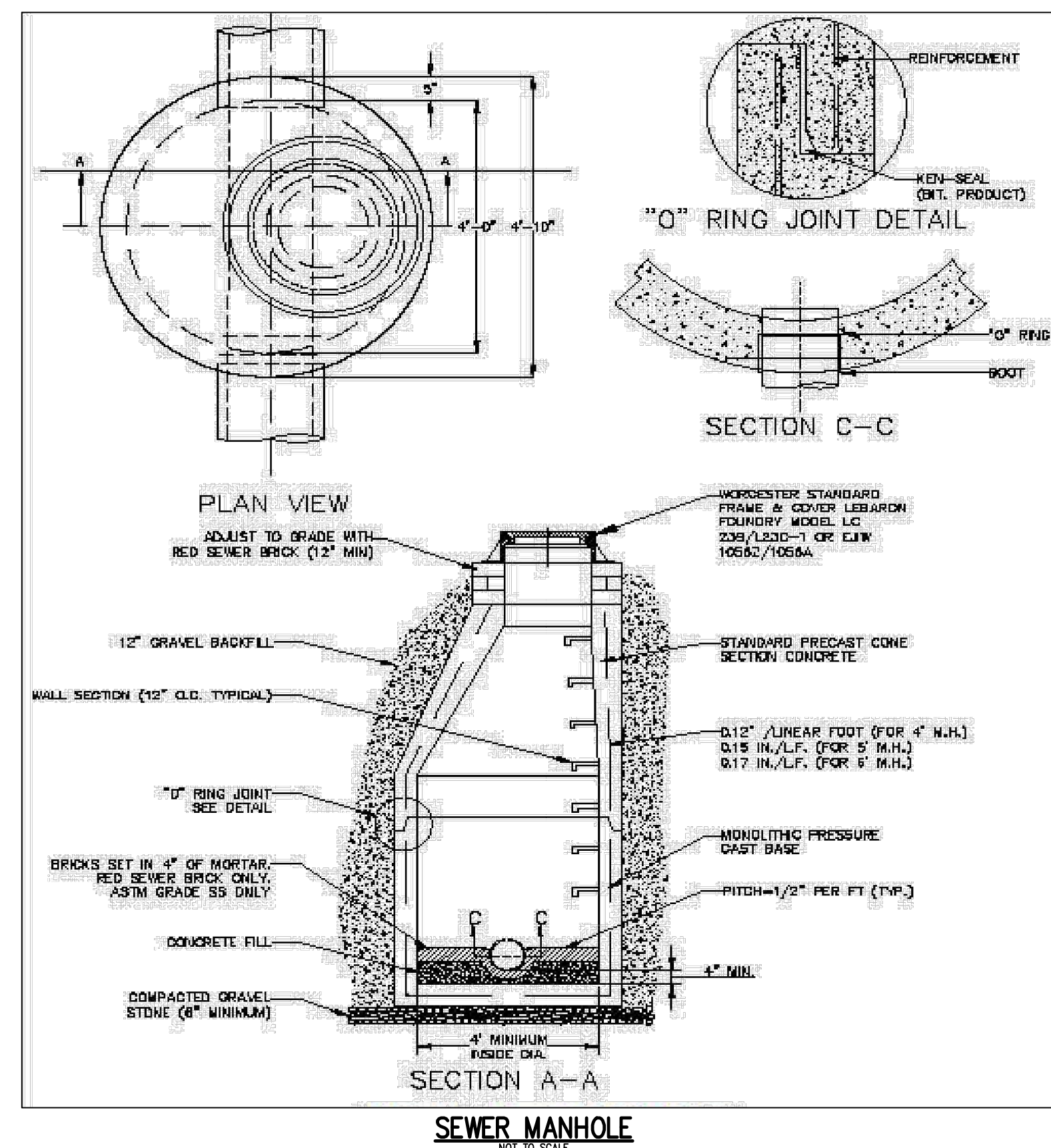

SEWER MANHOLE
NOT TO SCALE

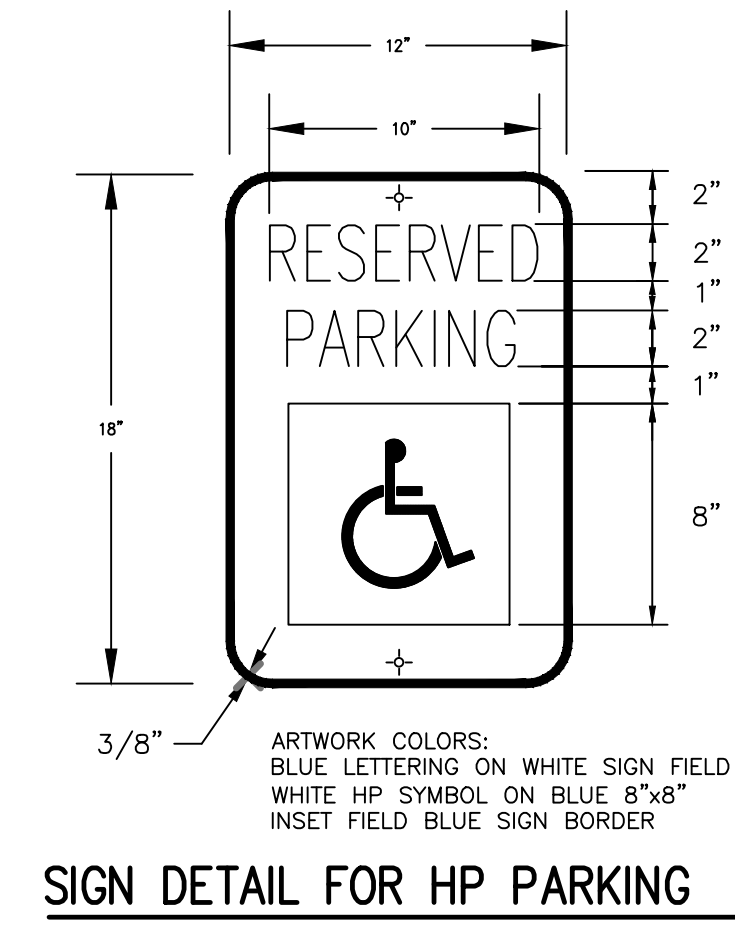

SIGN DETAIL FOR HP PARKING
NTS

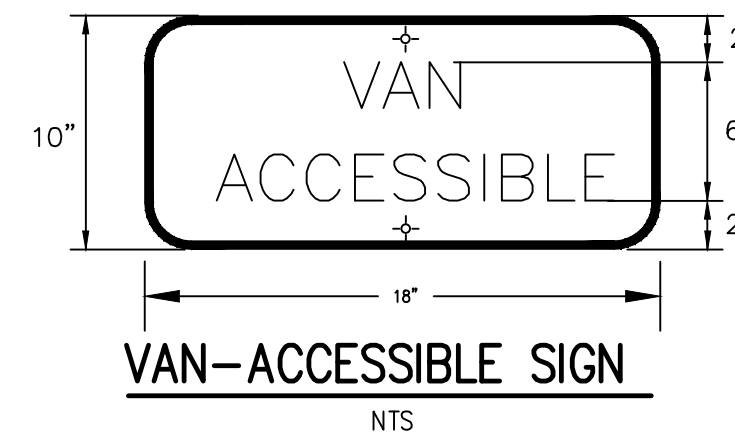

VAN-ACCESSIBLE SIGN
NTS

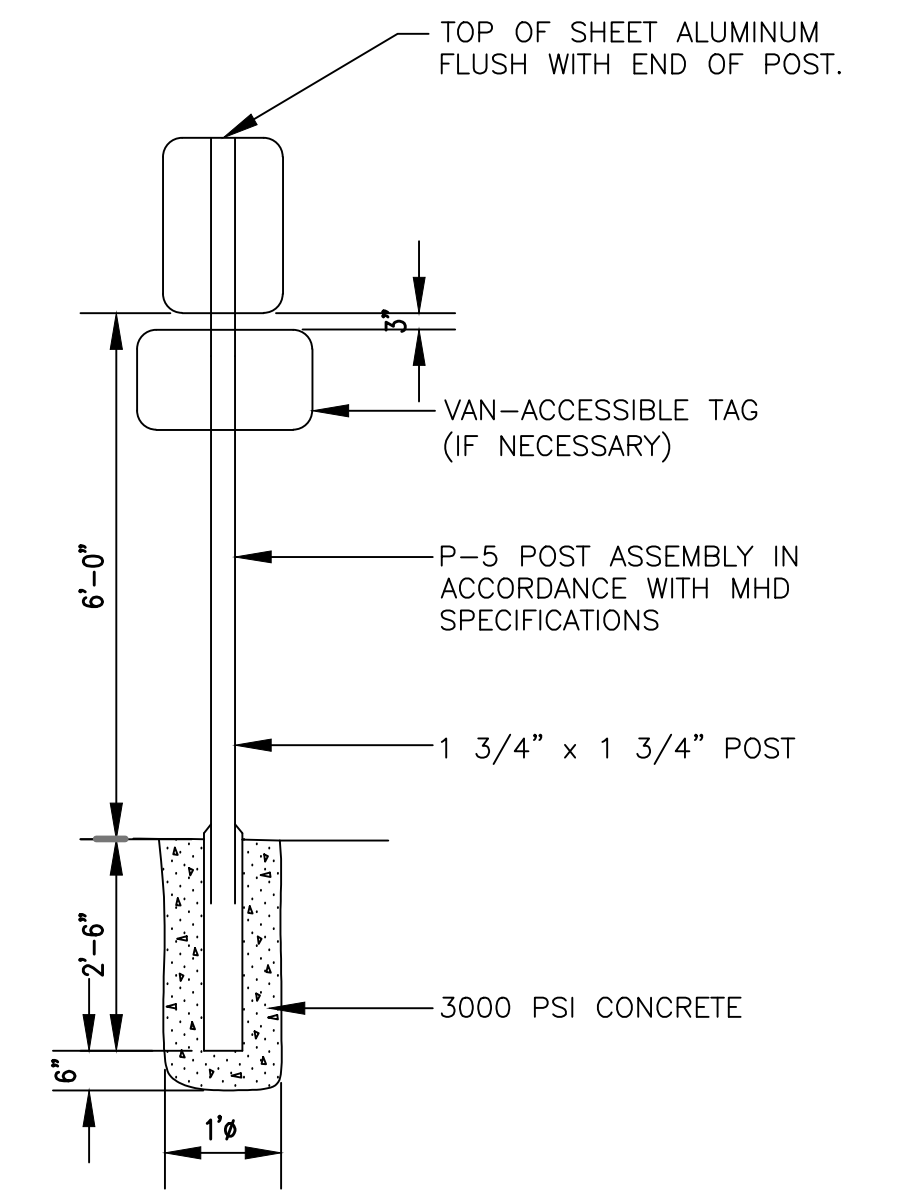

SIGN POST DETAIL
NTS

2	10/30/24	ZBA CONDITIONS OF APPROVAL
1	9/10/24	CITY COMMENTS
REV. NO.	DATE	REVISION

TITLE:
DEFINITIVE SITE PLAN
FOR
39 LAMARTINE STREET
WORCESTER, MASSACHUSETTS 01610

PREPARED FOR:
POLAR VIEWS, LLC
89 WEST MAIN STREET UNIT 101
NORTHBOROUGH, MASSACHUSETTS 01532

PROPERTY OWNER:
POLAR VIEWS, LLC
89 WEST MAIN STREET UNIT 101
NORTHBOROUGH, MASSACHUSETTS 01532

PREPARED BY:
J.M. GRENIER ASSOCIATES INC.
118 TURNPIKE ROAD SUITE 200
SOUTHBOROUGH, MASSACHUSETTS 01772

TELE NO.: (508) 845-2500 jmgrenier@townisp.com
SCALE: AS SHOWN DATE: JUNE 6, 2024

DETAIL PLAN 2/2

SHEET NO.: SHEET 8 OF 8 PROJECT NO.: G-647



10/30/24